

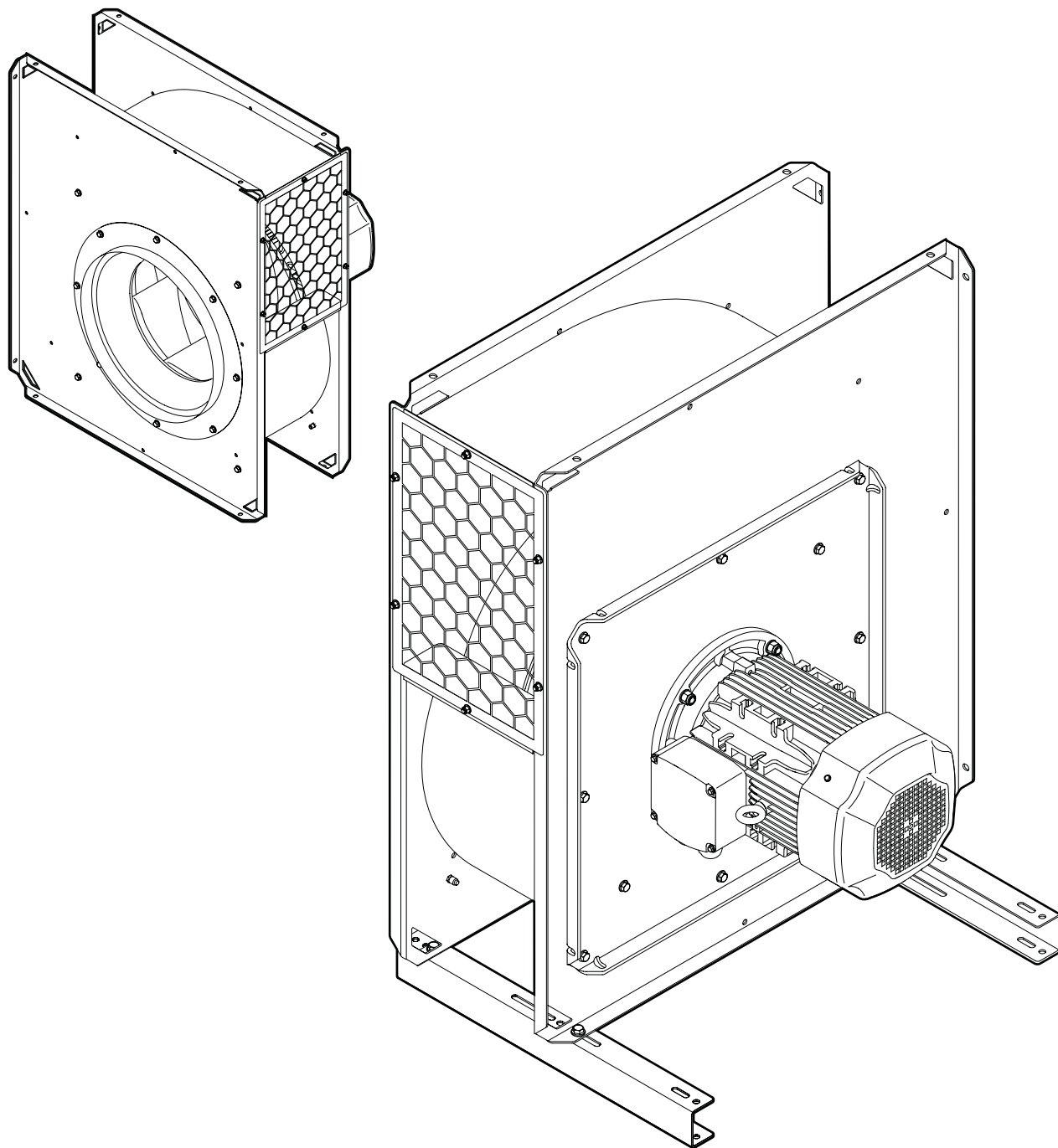

# FBE



# TABEL OF CONTENTS

<b>1 Introduction</b>	<b>3</b>	<b>5 Commissioning</b>	<b>11</b>
1.1 The manual	3	5.1 Start-up	11
1.2 Declaration	3		
1.3 Warranty	3	<b>6 Operation</b>	<b>11</b>
1.4 Manufacturer	3		
<b>2 Safety</b>	<b>4</b>	<b>7 Troubleshooting</b>	<b>12</b>
2.1 General	4	7.1 Troubleshooting guide	12
2.2 Protective equipment	4		
2.3 General warnings & information	4	<b>8 Maintenance</b>	<b>12</b>
		8.1 Cleaning	12
		8.2 Maintenance schedule	12
<b>3 Product Description</b>	<b>5</b>	<b>9 Decommissioning</b>	<b>13</b>
3.1 Serial number & product name	5	9.1 Final decommissioning/disassembly/disposal	13
3.2 Labels and safety signs	5		
3.3 Areas of use	6	<b>10 Technical information</b>	<b>13</b>
3.4 Design	6	10.1 Dimensional drawing	13
3.5 Function	6	10.1.1 FBE 037/075/150/220	13
		10.1.2 FBE 400/750/1100	14
<b>4 Preparation for use</b>	<b>7</b>	10.2 Technical data	14
4.1 Transport & storage	7	10.3 Circuit diagram electronics	15
4.2 Electrical equipment	7	10.3.1 FBE 037/075, 1-Phase	15
4.3 Assembly & installation	7	10.3.2 FBE 037/075/150/220, 3-Phase	15
4.3.1 Unpacking	7	10.3.3 FBE 400/750/110, 3-Phase	15
4.3.2 Moving the machine	7	10.4 Exploded-view drawing	16
4.3.3 Change of configuration	8		
4.3.4 Possible configurations	8	<b>11 Accessories</b>	<b>17</b>
4.3.5 Mounting the fan	9		
4.3.6 Installation	9	<b>12 Notes</b>	<b>18</b>
4.4 Accessory installation	10		
4.4.1 Flexible duct FDS	10		
4.4.2 Transition FBO	10		
4.4.3 Vibration damper Kit FBV M10	11		

## Foreword

FUMEX operates in the environmental technology sector and specialises in extraction arms, fans, and filters for all work environments. The company strives to create work environments free from airborne contaminants.

Our products are manufactured using modern methods and undergo extensive quality inspections. The products comply with applicable safety- and environmental requirements.

If you have any questions about FUMEX or our products, please contact your dealer or the FUMEX sales department.

# 1 Introduction

## 1.1 The manual

To ensure your knowledge of the product, you must read this manual before use.

The information in this manual is intended to facilitate the installation, operation, maintenance, troubleshooting, and repair of the product. The manual also provides the user with a technical understanding and basic safety instructions to minimise risks when working with the product, as well as to increase the product's service life.

The manual should be considered a part of the product and should always be accessible and in close proximity to the product.

The following symbols are referred to in the manual:



Safety instructions (applicable to people or machinery) that must always be adhered to. Risk of death or risk of personal injury or damage to property.



Recommendations which convey important information for an optimally functioning product.

## 1.2 Declaration

**CE** The product is CE certified and conforms to all applicable provisions in directives and standards as follows:

- Machinery Directive 2006/42/EC
- EMC Directive 2014/30/EU
- Safety of Machinery EN ISO 12100: 2010
- Electrical Equipment of Machines EN 60204-1
- Energy-related products ErP2015 2009/125/EC

For a full EC Declaration, please contact FUMEX.

## 1.3 Warranty

To preserve the validity of the warranty, it is forbidden to modify or re-engineer the product during the warranty period without first obtaining prior approval from FUMEX. This is also applicable to any spare parts used which do not correspond to the manufacturer's specifications.

Damage caused by improper use of the product will result in:

- the warranty being voided
- the EC Declaration and CE certification being voided.

The warranty period is one year from the date of purchase and covers the product and its constituent parts. All manufacturing defects are covered by the warranty. FUMEX replaces defective parts in accordance with NL 17.

FUMEX is not liable for any consequential or incidental damage, or any loss of income as a result of or in connection with the warranty case.

The onus is on the buyer to select the appropriate product for the intended use. Any modifications to the FUMEX product or its intended use will void the warranty.

## 1.4 Manufacturer

FUMEX AB  
Tel. no.: +46 910-361 80  
Email: info@fumex.se

Verkstadsvägen 2  
SE-931 61 Skellefteå  
Sweden

## 2 Safety

### 2.1 General

The product is safe to use. It is designed in such a way that hazardous parts are only located in inaccessible areas. Even so, if the product is not used correctly or as intended, it may be hazardous to the user or cause damage to the product. The user should therefore be informed and trained to handle the product's safety features.

### 2.2 Protective equipment

No special protective equipment is required to use the product. However, personal protective equipment such as safety glasses, respiratory protection, and safety gloves must be worn when cleaning the product.

### 2.3 General warnings & information



The product must not be modified.

The product must not be operated without safety devices.

Power to the machine must be switched off prior to maintenance, repair, or adjustment.

The machine may only be used in perfect technical condition and according to its intended use as described in Section **3.3 Areas of Use**. Faults that may jeopardise safety must be rectified immediately.

There is always a risk of loose objects being sucked into a fan, which can cause damage or injury.

The fan may cause harmful noise levels.

Work on the machine's electrical equipment may only be carried out by a licenced electrician in accordance with applicable local electrical safety regulations.

In the event of fire, hatches or service doors must not be opened.

The machine must not be used in a potentially explosive atmosphere or to extract dust and gases in explosive concentrations.

Damp/sticky dust must not be sucked into the fan. If this occurs, pre-filtration must be used or regular cleaning carried out.

All work on the machine must be carried out by certified and authorised personnel.

For maintenance work where contact with dust occurs, personal protective equipment such as safety glasses, respiratory protection, and safety gloves must be worn.



The surface on which the machine is installed must be appropriate for the mass of the machine.

Waste disposal must be carried out in accordance with the relevant national regulations.

### 3 Product Description

#### 3.1 Serial number & product name

Refer to the product nameplate.



#### 3.2 Labels and safety signs



Safety signs that are missing or illegible must be replaced before the machine is used.

According to Fig. 1.

1. Fumex logotype
2. Nameplate
3. Motor rotation arrow

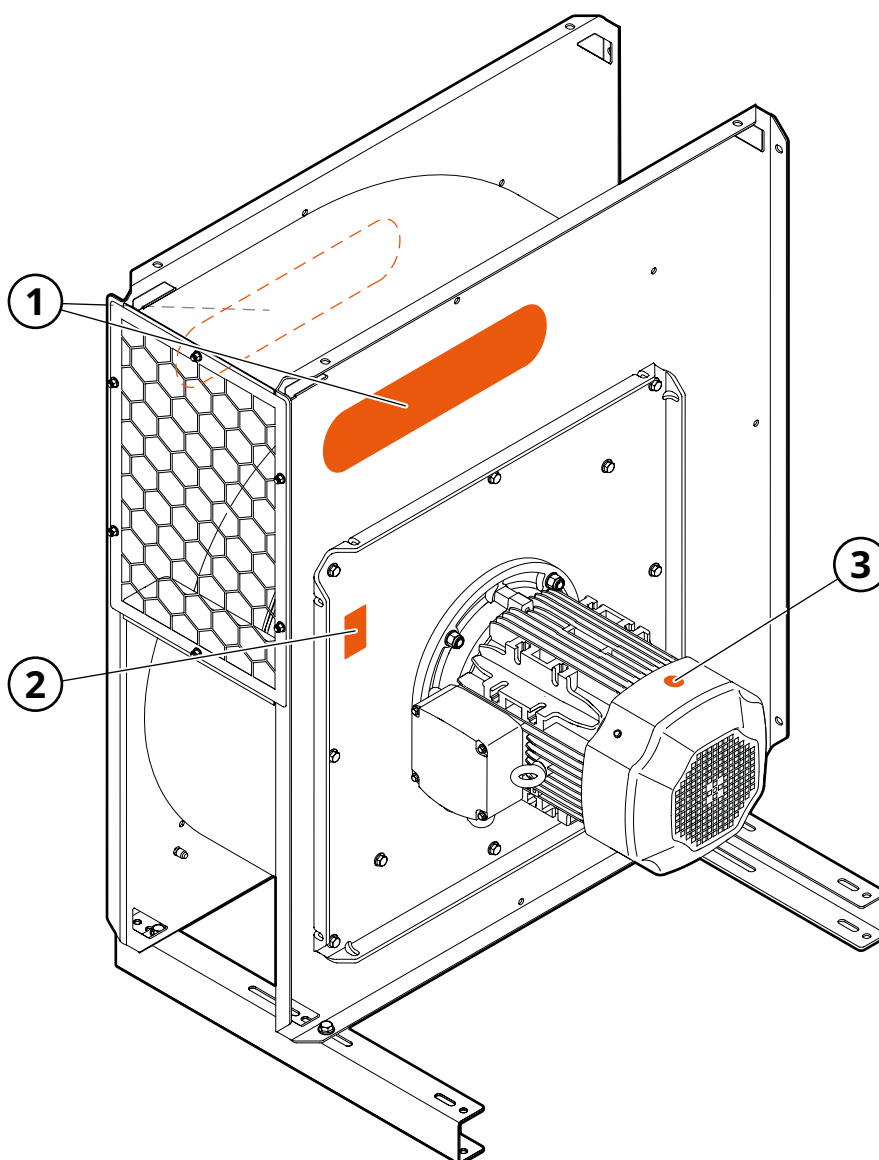
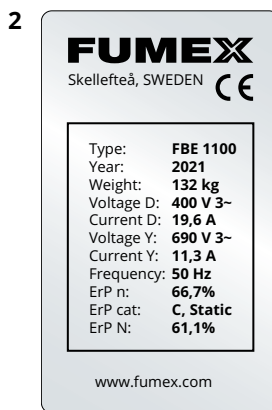

Fig. 1

### 3.3 Areas of use

Radial fan FBE is intended for use in the evacuation of gases, fumes and lighter particles.

### 3.4 Design

See Fig. 2.

- |                   |                         |
|-------------------|-------------------------|
| 1. Fan housing    | 8. Cooling air intake   |
| 2. Outlet         | 9. Cooling fan          |
| 3. Outlet grille  | 10. Lifting eye (motor) |
| 4. Mounting rail* | 11. Junction box        |
| 5. Lifting eye    | 12. Inlet cone          |
| 6. Motor plate    | 13. Impeller            |
| 7. Motor          | 14. Inlet               |

\* Included as standard on FBE 400/750/1100.

### 3.5 Function

Air is extracted through the inlet (14, Fig. 2) to the center of the fan wheel (13). The air is then transported through the fan wheel and evacuated through the fan outlet (2).

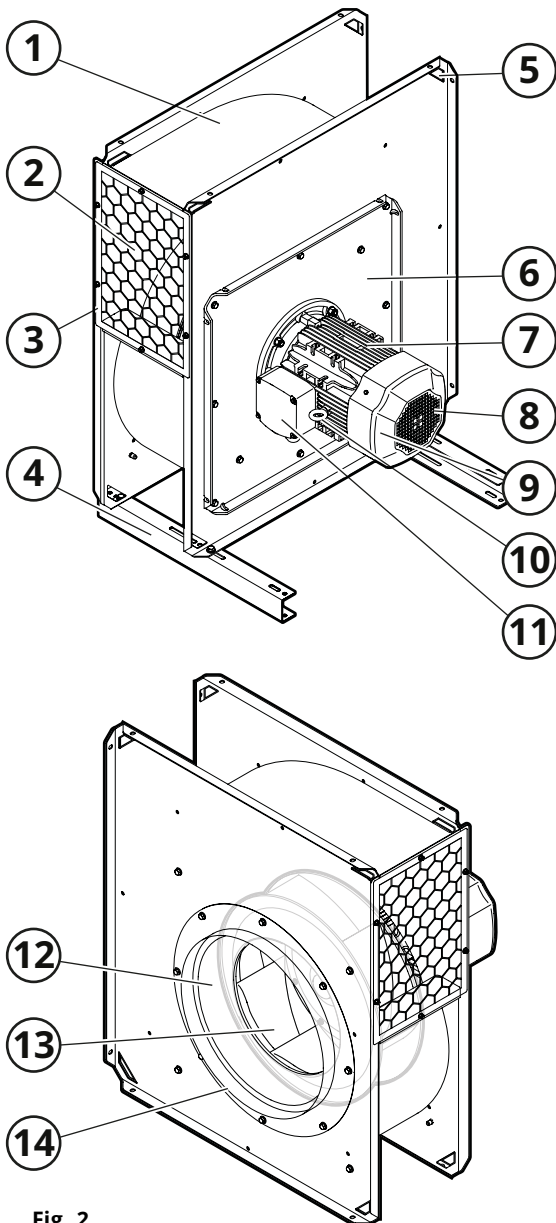

Fig. 2

## 4 Preparation for use



Never work or stand underneath suspended loads!

When lifting and/or replacing parts, it is important that the lifting device is stable and secured. Only use suitable and technically sound lifting gear and load-bearing equipment with sufficient capacity.

### 4.1 Transport & storage



Protect the machine and its parts from rain, snow, aggressive atmospheres and other harmful effects.

### 4.2 Electrical equipment



The equipment is fed with high voltage and must always be equipped with a safety switch for service work in connection with the fan.

To meet the applicable standards, the fan must always be equipped with a protective motor switch and an overcurrent protection (not applicable when feeding from frequency converters).



If control devices (e.g. frequency converters) are used, the manufacturer's recommendations to avoid interference are followed. For example, EMC, protective earth, cable-length cable shielding, etc.

The choice of cable and cable area must comply with the national requirements applicable to fixed installations. For electrical installation, see Section **10.2 Circuit diagram electronics**.

## 4.3 Assembly & installation

National rules and regulations must always be adhered to during assembly work.

### 4.3.1 Unpacking



Consider tipping risk.

1. Carefully unpack the product.
2. If the fan has been delivered on a pallet, remove the wood screws securing the fan to the pallet.
3. Check for any damage and missing parts. Contact a local Fumex representative directly if there is damage or parts are missing.
4. Dispose of the packaging material according to local recycling regulations.

### 4.3.2 Moving the machine



When moving, use the lifting eyes designed for lifting with a round loop rated for 1 tonne, so as not to damage powder coated surfaces. See **Fig. 3**.

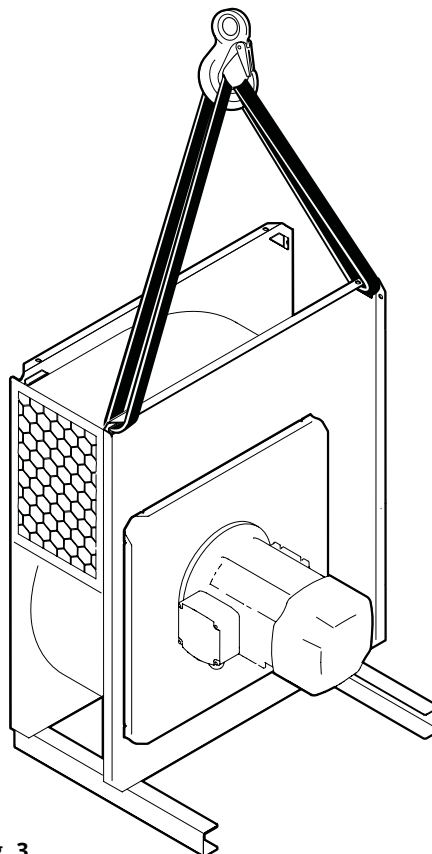

Fig. 3

### 4.3.3 Change of configuration



Take care when installing/uninstalling motor packages so that fan wheels are not damaged.

The motor package must always be installed so that the cable connection is facing downwards after installation.

When installing motor packages, apply liquid gasket for sealing between the motor plate and fan housing. Fumex recommends the **HYLOMAR** brand.

#### Procedure

Upon modification of configuration, refer to **Fig. 4** and **Fig. 5**.

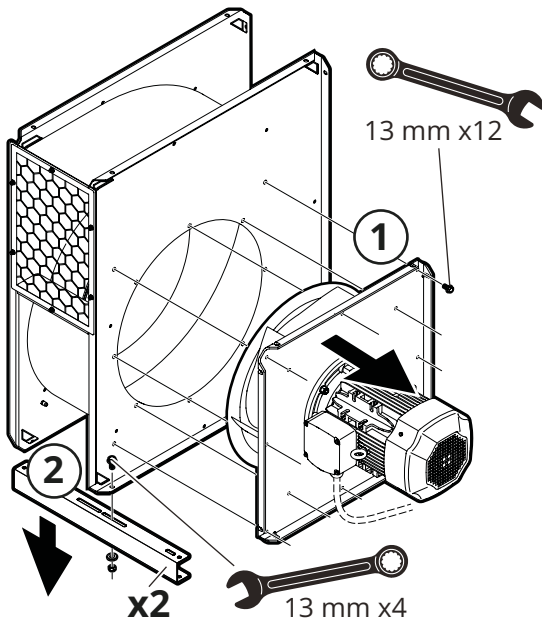

Fig. 4

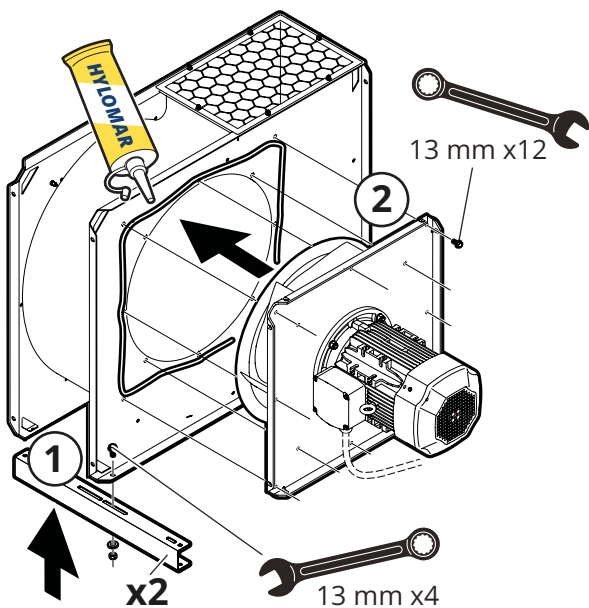

Fig. 5

### 4.3.4 Possible configurations

#### LG 0

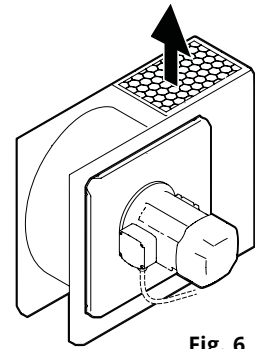

Fig. 6

#### LG 90\*



\* Standardised delivery version.

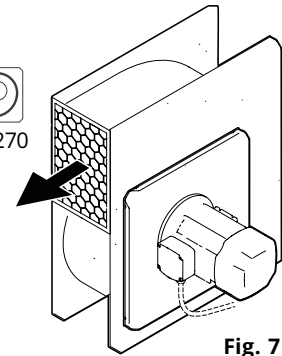

Fig. 7

#### LG 180

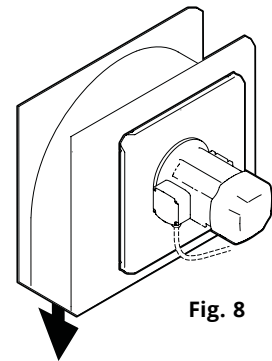

Fig. 8

#### LG 270

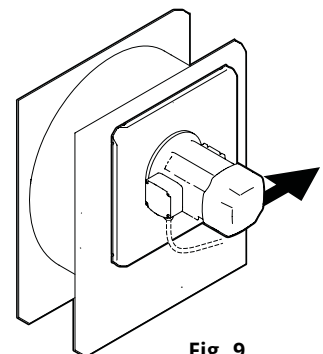

Fig. 9

### 4.3.5 Mounting the fan



The fan must never be installed with the motor facing downwards.



For outdoor installation and configuration of LG 0/90/180, a drainage hole must be drilled into what will be the lowest point of the fan housing on the pre-mounted fan. Always protect the drilled hole from corrosion.

Exhausts at risk of the direct effects of precipitation should be appropriately protected.

The motor must always be installed so that the cable connection is facing downwards.

The sound level should - if possible - be optimized with regard to the user. The highest sound level follows the outlet direction.

#### 4.3.5.1 Recommended outdoor installation

The recommended outdoor installation is shown below without a connected outlet duct. Note that the recommendation differs from standard the delivery configuration and that a site-built foundation/bracket is required to optimise the fan's conditions for operation and performance.

##### 4.3.5.1.1 Low side-directed outlet direction

Low side-directed outlet direction provides optimal power and does not require drainage as the outlet is the lowest point. Suitable in the event of condensation problems.

#### On roofs



At locations with heavy precipitation, foundations must be built on site. See Fig. 10.

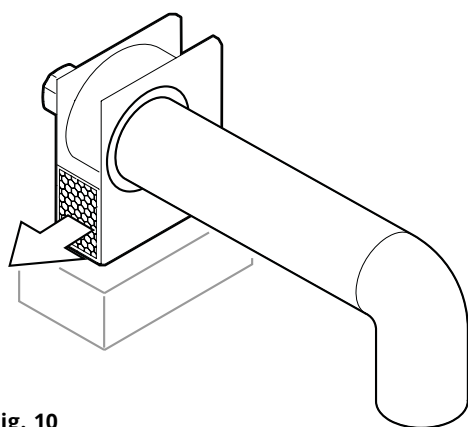

Fig. 10

#### On facades

Wall mounting on bracket according to Fig. 11 optimises pressure drops on the inlet side.

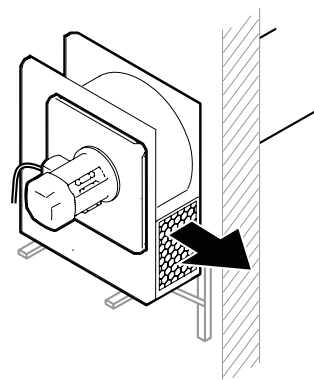

Fig. 11

### 4.3.6 Installation



The fan is designed for installation in an industrial plant and therefore has no contact guard at the inlet. This entails that the fan must not be started until it is connected to the duct.

The contact guard mounted on the outlet is removable if you wish to connect an outlet duct. The contact guard must be replaced by a guard to prevent the entry of children and animals if removed.

The stability of the fan must always be assured during operation. For optimal operation, it is important that the fan duct connections are properly executed. Incorrect installation can cause major deterioration in fan performance, in terms of pressure drops and sound.

For optimal performance, Fumex recommend that the couplings are straight and at least 5 times the diameter of the duct. If the system requires a 90° bend at the outlet, it should bend off in the direction of the fan wheel rotation; see Fig. 12.

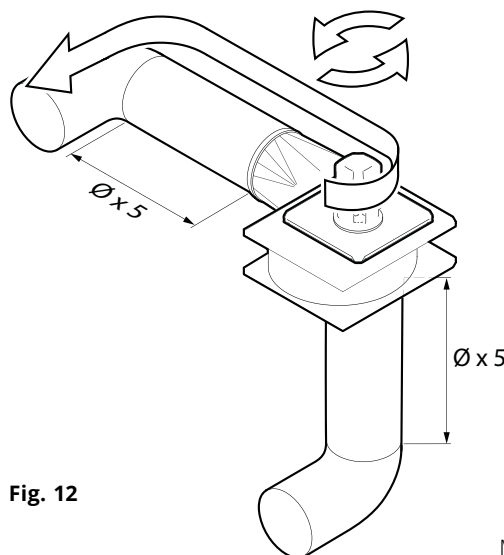

Fig. 12

## 4.4 Accessory installation



Accessories, ordered separately.  
Refer to Chapter 11 Accessories.

### 4.4.1 Flexible duct FDS

FDS 250

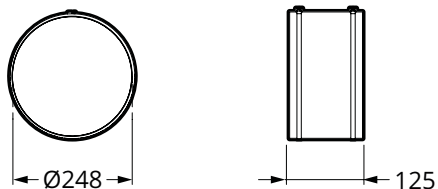

FDS 315

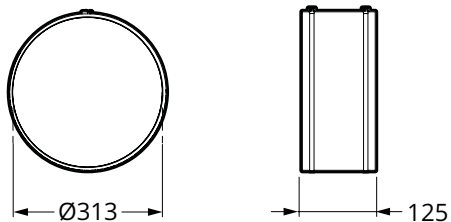

FDS 400

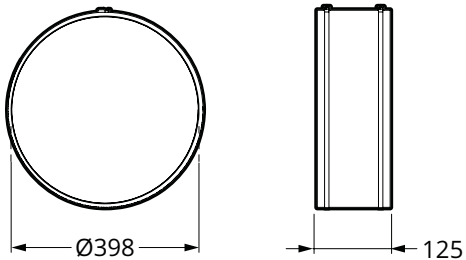

FDS 500

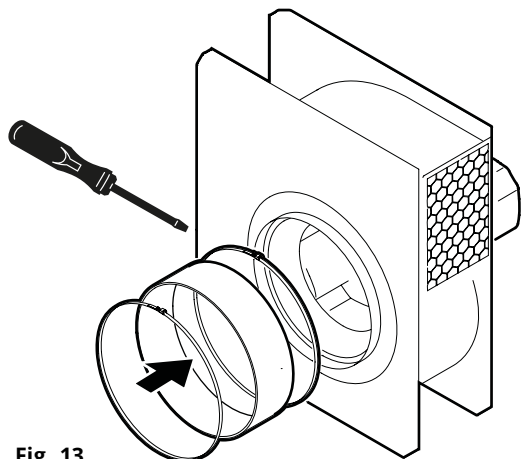
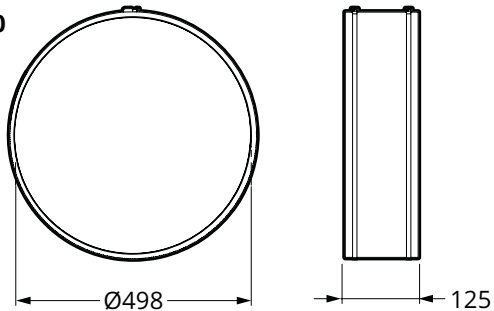
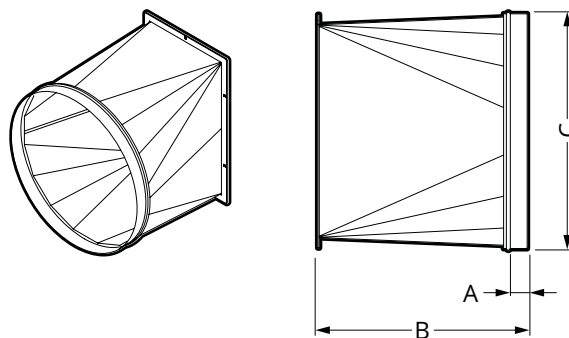

Fig. 13

### 4.4.2 Transition FBO



Dimensions (mm)	A	B	C
FBO 037	35	245	Ø248
FBO 075	35	245	Ø248
FBO 150	35	245	Ø313
FBO 220	35	255	Ø313
FBO 400	35	345	Ø398
FBO 750	35	445	Ø498
FBO 1100	35	445	Ø498

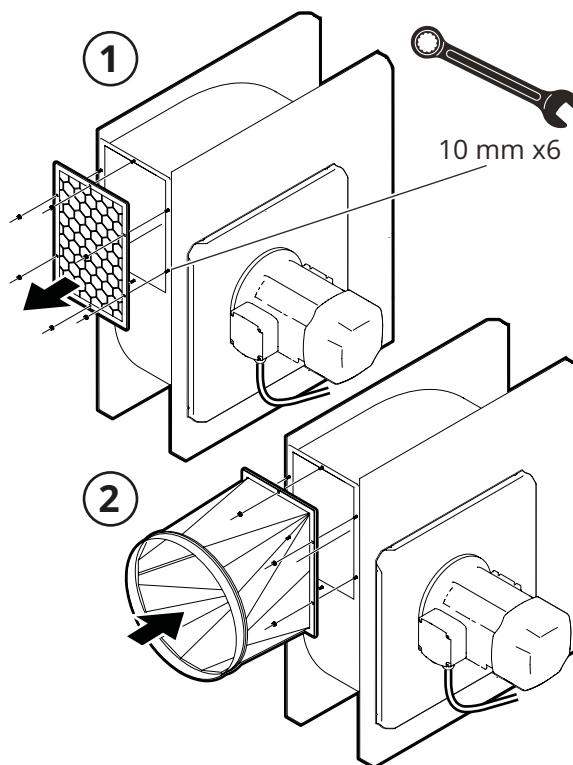

Fig. 14

### 4.4.3 Vibration damper Kit FBV M10

Mount to fan

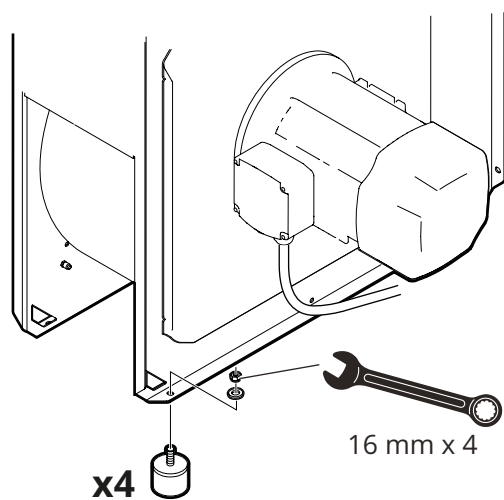

Fig. 15

Mount to mounting rail FBEK

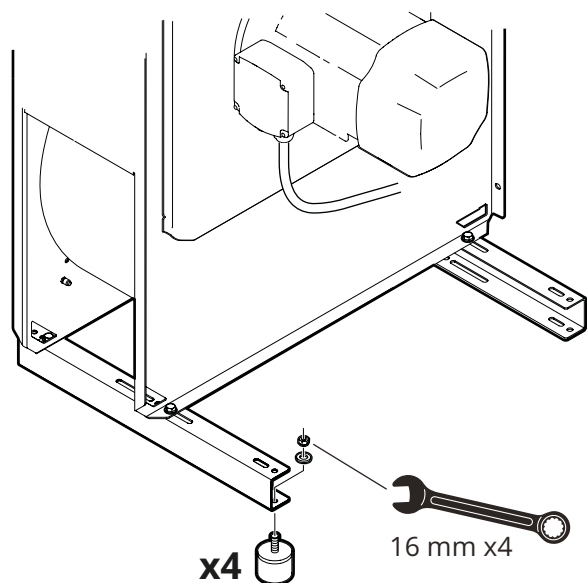

Fig. 16

## 5 Commissioning

### 5.1 Start-up



Any faults must be rectified before turning on the power.

1. Start the fan.



If the machine's overcurrent protection is tripped, power consumption is too high. Please contact Fumex.

2. Check the fan motor's direction of rotation. The fan motor's direction of rotation is checked by starting the fan, then stopping the fan. As the speed decreases, you can see which way the motor is rotating through the cooling air intake (pos. 7, Fig. 2.) If the direction of rotation is incorrect, the phase coupling in the motor terminal block is reversed.

3. Check the rotational direction again.

4. Turn off the fan.

The fan is now ready for operation.

## 6 Operation



The fan motor generates heat and is equipped with a cooling fan (pos 8, Fig. 2.) The cooling fan inlet (8) is located at the back of the motor. Do not block the inlet.

Note that electric equipment is always sensitive to static electricity, high humidity, high temperature, and grid disruption.

# 7 Troubleshooting



Troubleshooting with the power switched on may only be carried out by a licenced electrician.

## 7.1 Troubleshooting guide

The troubleshooting guide contains information for identifying faults which are simple to rectify. Always perform the troubleshooting procedures before contacting FUMEX.

TROUBLESHOOTING GUIDE		
Symptom	Possible cause	Recommended action
1. Fan has stopped.	Connector short circuit	Check for moisture in the motor connection.
	Power supply problem	Check power supply.
	Stuck impeller	Check for any foreign objects in the fan housing.
		Check that no ice has formed in the fan housing.
	Make sure motor bearings are functioning.	
1. Fan performance loss.	Incorrect rotational direction	Check rotational direction.
	Debris	Check for any foreign objects in the fan housing.
	Connections	Check that connections and duct routing are correct.
	Motor winding	Check the resistance between windings.

# 8 Maintenance



Please remember that only original spare parts may be used.

Make sure that all moving parts are secured to prevent unintentional movement.

## 8.1 Cleaning

The product should be cleaned with clean cloths and neutral detergents to avoid damage.

## 8.2 Maintenance schedule



Depending on the changing operating conditions between the different systems, the intervals for recommended maintenance may differ. Users should therefore determine their own maintenance intervals.

The checklist for maintenance is designed for normal use of the machine. The recommended intervals are approximate and refer to the time after the first start-up.

FUMEX recommends the following maintenance schedule:

MAINTENANCE SCHEDULE				
Interval	Item	Inspection module	Maintenance instructions	Date
When necessary	1.1	Fan	Clean exterior. See section <b>8.1 Cleaning</b> .	
	2.1	Electrical equipment	Check all electrical equipment for visible external damage. Replace if necessary.	
Every six months	2.2	Fan housing	Check for leaks, damage and wear.	
	2.3	Motor	Check functionality. Replace if necessary.	
	2.4	Impeller	Check for any damage and clear away foreign objects if necessary. Replace a damaged impeller.	
	2.5	Fan housing	Check that connections are secure and clear away foreign objects. Check the drainage hole and clear if necessary.	

## 9 Decommissioning

### 9.1 Final decommissioning/ disassembly/disposal

Final decommissioning and disassembly of the product may only be done by authorised personnel wearing protective gear. The handling and correct removal of the various types of materials must be in accordance with the applicable legal requirements.

Please contact FUMEX if you have any questions about the various types of waste.

## 10 Technical information

### 10.1 Dimensional drawing

#### 10.1.1 FBE 037/075/150/220

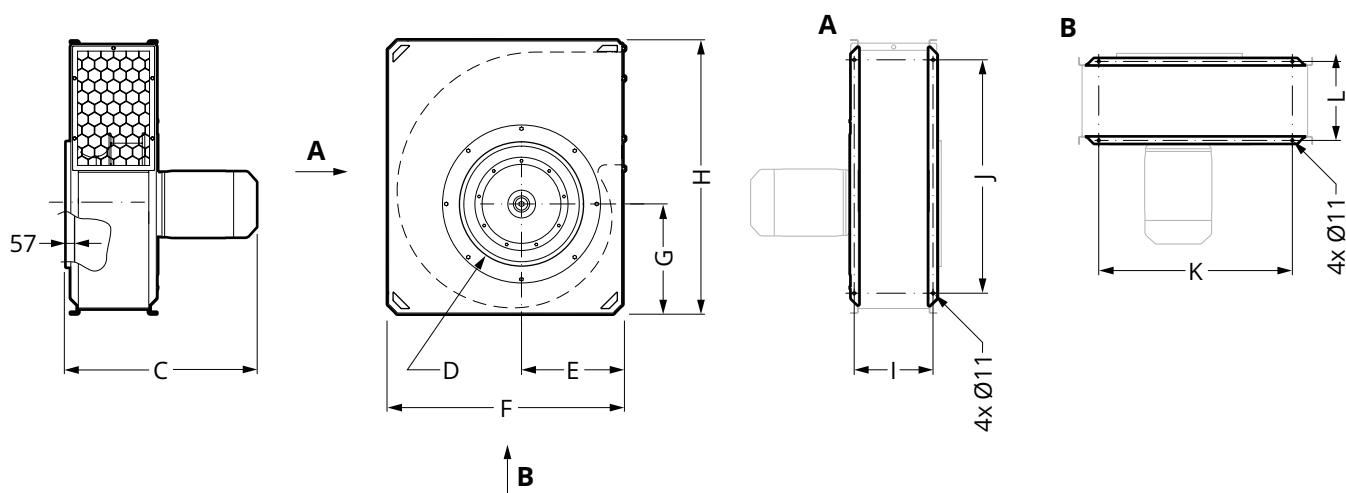

Version	Dimensions (mm)									
	C	D	E	F	G	H	I	J	K	L
FBE 037	435	Ø248	183	430	212	520	183	360	270	183
FBE 075	492	Ø248	205	475	239	580	201	420	315	201
FBE 150	526	Ø313	230	535	265	645	235	485	375	235
FBE 220	606	Ø313	258	600	301	730	245	570	440	245

### 10.1.2 FBE 400/750/1100

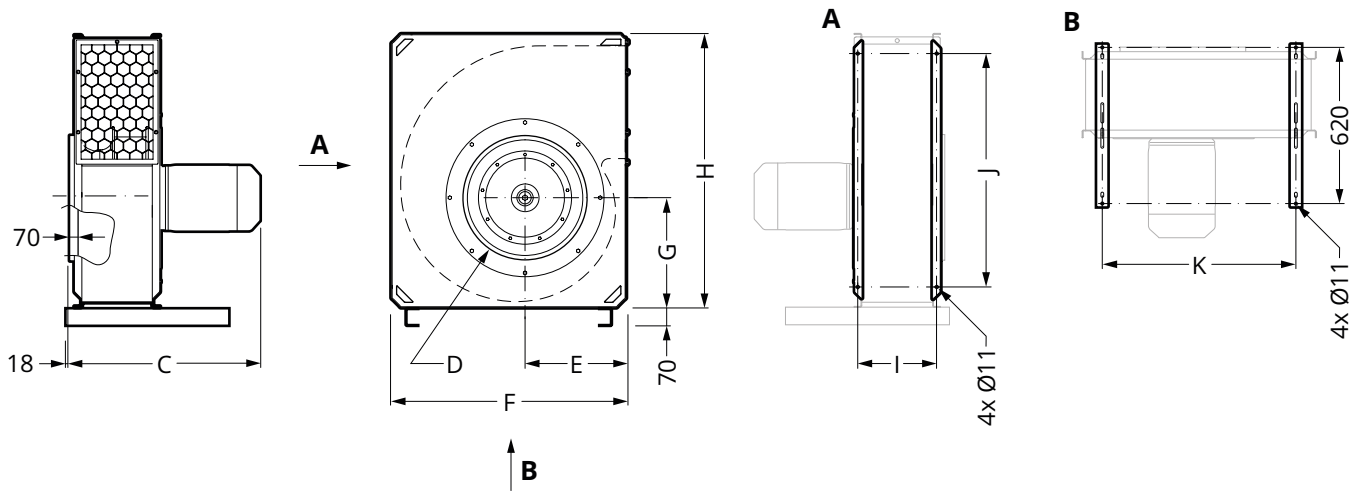

Version	Dimensions (mm)								
	C	D	E	F	G	H	I	J	K
FBE 400	722	Ø398	297	720	249	880	267	720	560
FBE 750	783	Ø498	330	805	385	970	310	810	645
FBE 1100	809	Ø498	400	930	435	1085	313	925	770

## 10.2 Technical data

Model: .....	FBE 037	FBE 075	FBE 150	FBE 220	FBE 400	FBE 750	FBE 1100
Dimensions: .....	See section 10.1 Dimensional drawing.						
Weight: .....	23 kg	30 kg	40 kg	58 kg	94 kg	136 kg	162 kg
Voltage: .....	230 V 1N~/230 V 3~/400 V 3~	230 V 1N~/230 V 3~/400 V 3~	230/400 V 3~	230/400 V 3~	400/690 V 3~	400/690 V 3~	400/690 V 3~
Frequency: .....	50 Hz	50 Hz	50 Hz	50 Hz	50 Hz	50 Hz	50 Hz
Power: .....	0,37 kW	0,75 kW	1,5 kW	2,2 kW	4,0 kW	7,5 kW	11,0 kW
Current: .....	2,9/1,7/0,96 A	5,8/3,3/1,9 A	5,3/3,1 A	7,6/4,3 A	7,4/4,3 A	13,5/7,8 A	19,6 A/11,3 A
Speed: .....	2755 rpm	2890 rpm	2890 rpm	2890 rpm	2910 rpm	2940 rpm	2950 rpm
Enclosure class: ..	IP55	IP55	IP55	IP55	IP55	IP55	IP55
Sound level $L_p$ *: ..	70 dB (A)	76 dB (A)	81 dB (A)	84 dB (A)	88 dB (A)	91 dB (A)	94 dB (A)

#### Temperature limits

Max. operating temperature: .....80 °C  
 Ambient temperature: .....-20 °C till +40 °C  
 Transport & storage temperature: .....-25 °C till +60 °C  
 Max. humidity: .....80 %

\* Sound pressure level at energy-optimal operating point one meter from fan at hemispherical sound propagation in free field.

### 10.3 Circuit diagram electronics

#### 10.3.1 FBE 037/075, 1-Phase

Clockwise

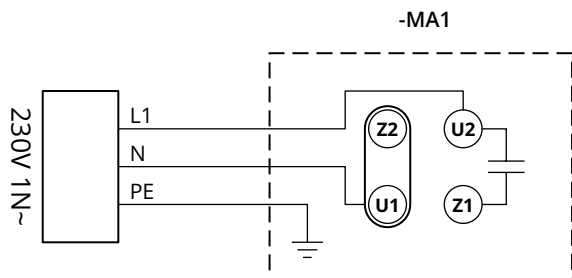

Counter clockwise

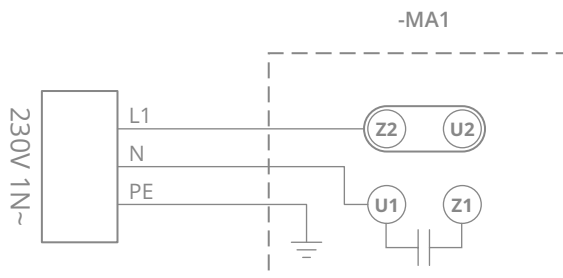

#### 10.3.2 FBE 037/075/150/220, 3-Phase

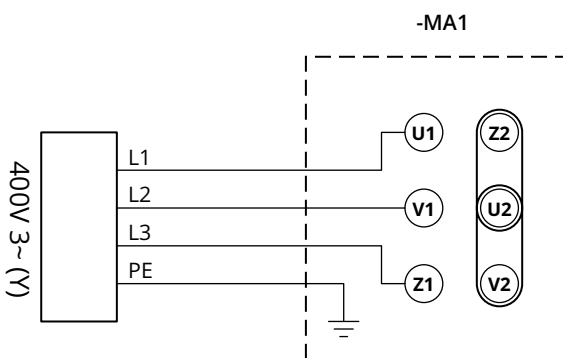
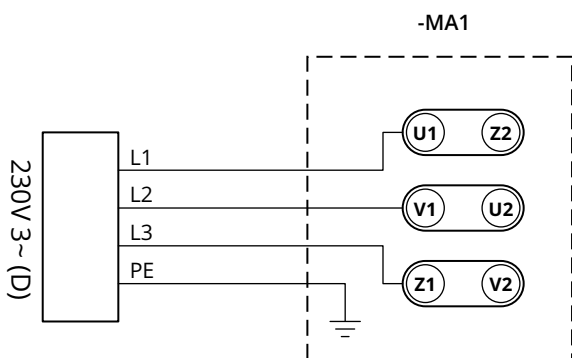

#### 10.3.3 FBE 400/750/1100, 3-Phase

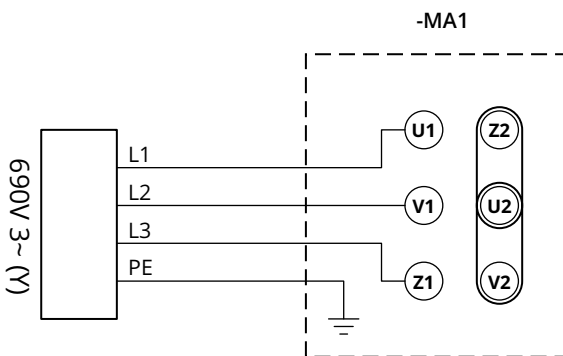
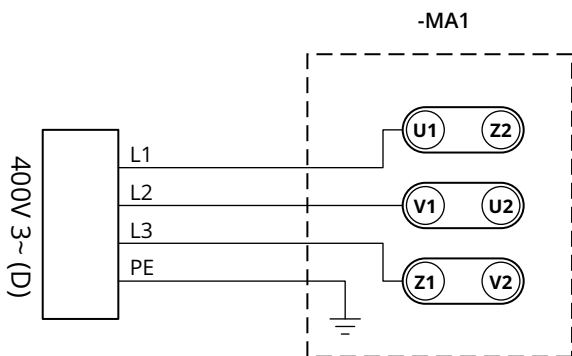

### 10.4 Exploded-view drawing

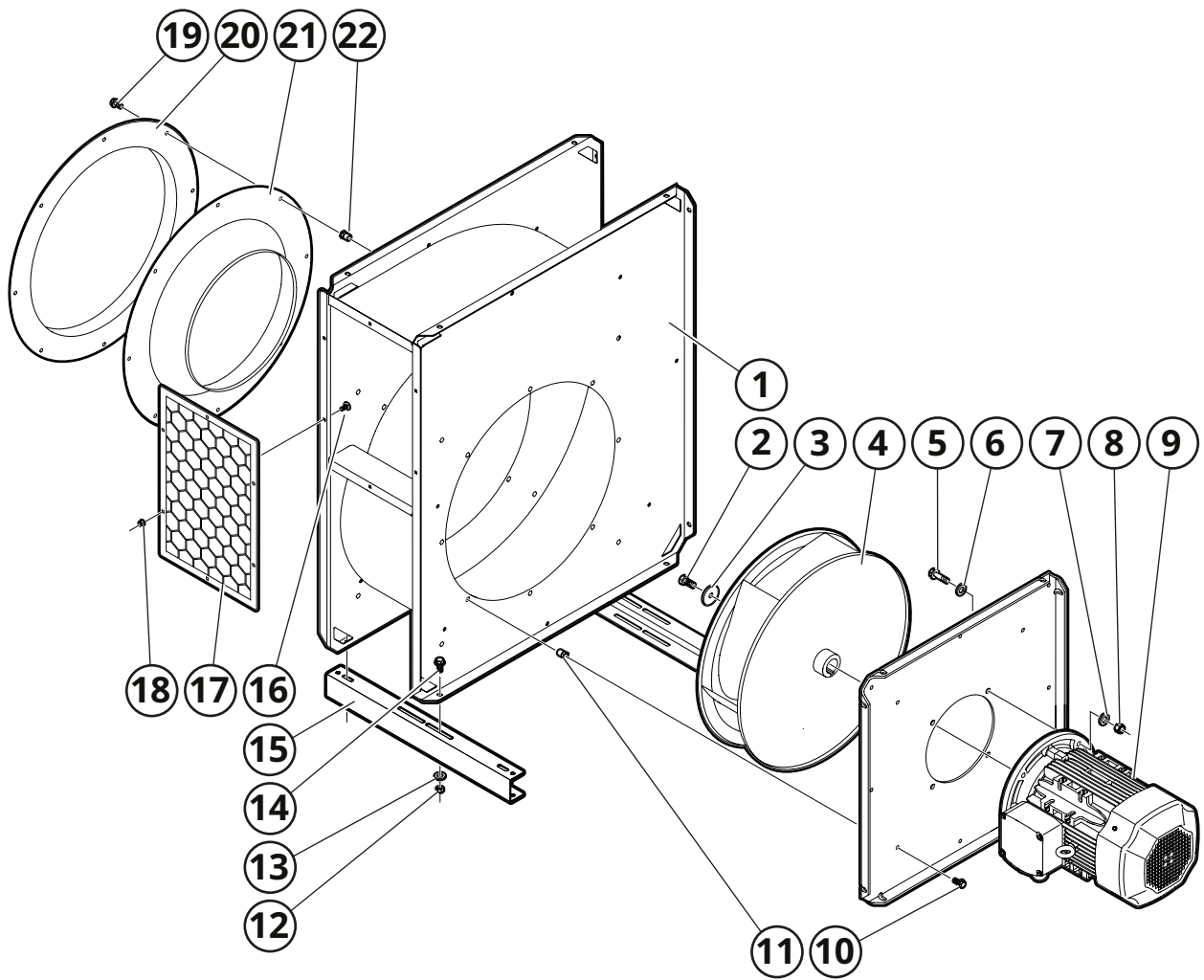

# 11 Accessories

## Transition FBO

Transition from rectangular to round coupling.

Fig. 17

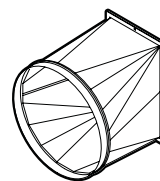

## Flexible duct FDS

For connection to the suction side, including 2 mounting clamps.

Fig. 18



## Vibration damper Kit FBV M10

Kit with four vibration dampers in natural rubber with hardness 60° IRH. Prevents the spread of vibrations.

Fig. 19

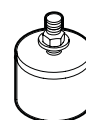

## Safety switch SSB

With lockable toggle. Two M25 penetrations included.

Fig. 20

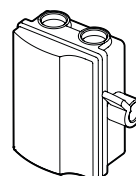

## Safety switch SSB EMC

For operation via frequency converter. Copper-sheathed with lockable toggle. Two M25 bushings included.

Fig. 21

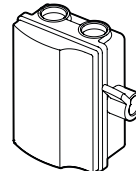

## Contactor SKO

3-pin contactor with overcurrent relay for manual reset. The overcurrent relay has phase loss protection. Used in together with external switches or control.

Fig. 22

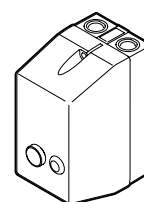

## Motor protection switch SMB

3-pin motor protection switch with thermal magnetic release equipped with phase fault protection. Designed for operating and protecting fan motors.

Fig. 23

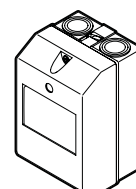

## Mounting rail FBEK

For easy and safe installation.

Fig. 24

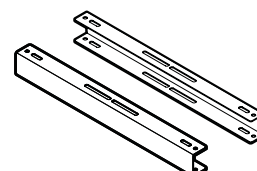

## **12 Notes**



EXTRACTION ARMS · VEHICLE EXHAUST EXTRACTION · FANS · FILTERS · CURTAINS · CONTROLS

**FUMEX**

Verkstadsvägen 2, 93161 Skellefteå, Sweden • Tel.: +46 910-361 80 • Fax: +46 910-130 22 • E-mail: [info@fumex.se](mailto:info@fumex.se)  
[www.fumex.com](http://www.fumex.com)