

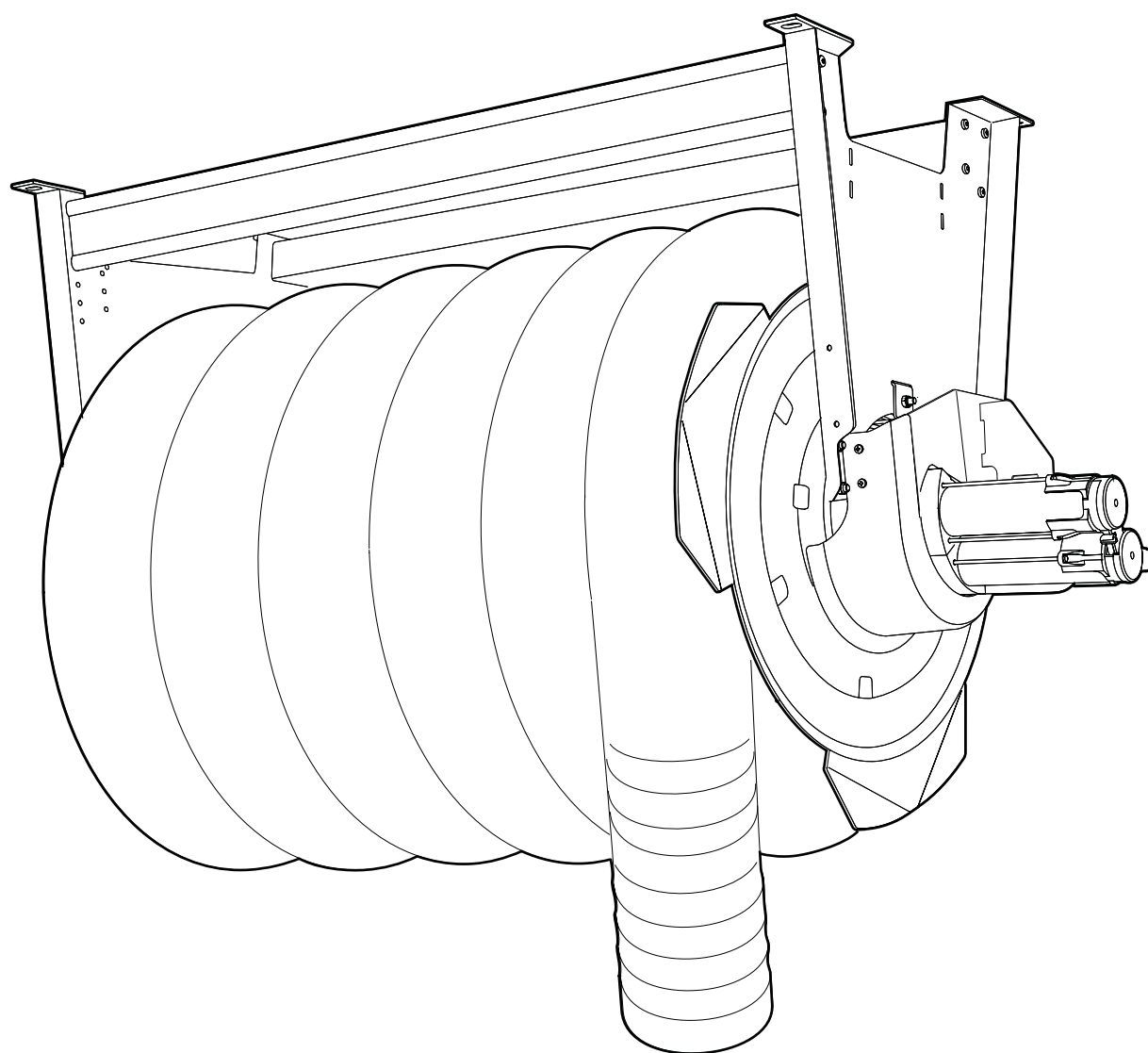

ASEM 130



TABEL OF CONTENTS

1 Introduction	3	5 Commissioning	9
1.1 The manual	3	5.1 Start-up	9
1.2 Declaration	3		
1.3 Warranty	3	6 Operation	9
1.4 Manufacturer	3		
2 Safety	4	7 Troubleshooting	10
2.1 General	4	7.1 Troubleshooting guide	10
2.2 Protective equipment	4		
2.3 General warnings & information	4	8 Maintenance	10
		8.1 Cleaning	10
		8.2 Maintenance schedule	10
3 Product Description	5		
3.1 Serial number & product name	5	9 Decommissioning	11
3.2 Labels and safety signs	5	9.1 Final decommissioning/disassembly/disposal	11
3.3 Areas of use	5		
3.4 Design	5	10 Technical information	11
3.5 Function	5	10.1 Technical data	11
		10.2 Circuit diagram electronics	12
		10.2.1 ASEM 1 / ASEM 2	12
		10.2.2 ASEM Radio	12
		10.3 Exploded-view drawing	13
4 Preparation for use	6		
4.1 Transport & storage	6	11 Accessories	14
4.2 Electrical equipment	6		
4.3 Assembly & installation	6	12 Notes	15
4.3.1 Unpacking	6		
4.3.2 Moving the machine	6		
4.3.3 Hose reel excluding hose	6		
4.3.4 Declutching the motor	7		
4.3.5 Installing the hose	7		
4.3.6 Mounting the hose reel	8		
4.3.7 Installation	9		
4.3.8 Adjusting the end positions	9		

Foreword

FUMEX operates in the environmental technology sector and specialises in extraction arms, fans, and filters for all work environments. The company strives to create work environments free from airborne contaminants.

Our products are manufactured using modern methods and undergo extensive quality inspections. The products comply with applicable safety- and environmental requirements.

If you have any questions about FUMEX or our products, please contact your dealer or the FUMEX sales department.

1 Introduction

1.1 The manual

To ensure your knowledge of the product, you must read this manual before use.

The information in this manual is intended to facilitate the installation, operation, maintenance, troubleshooting, and repair of the product. The manual also provides the user with a technical understanding and basic safety instructions to minimise risks when working with the product, as well as to increase the product's service life.

The manual should be considered a part of the product and should always be accessible and in close proximity to the product.

The following symbols are referred to in the manual:



Safety instructions (applicable to people or machinery) that must always be adhered to. Risk of death or risk of personal injury or damage to property.



Recommendations which convey important information for an optimally functioning product.

1.2 Declaration

CE The product is CE certified and conforms to all applicable provisions in directives and standards as follows:

- Machinery Directive 2006/42/EC
- EMC Directive 2014/30/EU
- Safety of Machinery EN ISO 12100: 2010
- Electrical Equipment of Machines EN 60204-1
- Energy-related products ErP2015 2009/125/EC

For a full EC Declaration, please contact FUMEX.

1.3 Warranty

To preserve the validity of the warranty, it is forbidden to modify or re-engineer the product during the warranty period without first obtaining prior approval from FUMEX. This is also applicable to any spare parts used which do not correspond to the manufacturer's specifications.

Damage caused by improper use of the product will result in:

- the warranty being voided
- the EC Declaration and CE certification being voided.

The warranty period is one year from the date of purchase and covers the product and its constituent parts. All manufacturing defects are covered by the warranty. FUMEX replaces defective parts in accordance with NL 17.

FUMEX is not liable for any consequential or incidental damage, or any loss of income as a result of or in connection with the warranty case.

The onus is on the buyer to select the appropriate product for the intended use. Any modifications to the FUMEX product or its intended use will void the warranty.

1.4 Manufacturer

FUMEX AB
Tel. no.: +46 910-361 80
Email: info@fumex.se

Verkstadsvägen 2
SE-931 61 Skellefteå
Sweden

2 Safety

2.1 General

The product is safe to use. It is designed in such a way that hazardous parts are only located in inaccessible areas. Even so, if the product is not used correctly or as intended, it may be hazardous to the user or cause damage to the product. The user should therefore be informed and trained to handle the product's safety features.

2.2 Protective equipment

No special protective equipment is required to use the product. However, personal protective equipment such as safety glasses, respiratory protection, and safety gloves must be worn when cleaning the product.

2.3 General warnings & information



The product must not be modified.

The product must not be operated without safety devices.

Power to the machine must be switched off prior to maintenance, repair, or adjustment.

The machine may only be used in perfect technical condition and according to its intended use as described in Section **3.3 Areas of use**. Faults that may jeopardise safety must be rectified immediately.

Work on the machine's electrical equipment may only be carried out by a licenced electrician in accordance with applicable local electrical safety regulations.

The machine's moving parts always constitute a risk (e.g. cutting, clamping or gripping points).

Under no circumstances should water be used to extinguish/cool in the event of a fire or heat generation. A powder extinguisher or other suitable extinguisher must be used instead.

Explosive gases must not be transported in the hose!

The machine must not be used in a potentially explosive environment or to extract dust and gases in explosive concentrations.

All work on the machine must be carried out by certified and authorised personnel.

For maintenance work where contact with dust occurs, personal protective equipment such as safety glasses, respiratory protection and safety gloves must be worn.



The surface on which the machine is installed must be appropriate for the mass of the machine.

Regardless of the manual, the machine is subject to national and local safety and accident prevention regulations.

Waste disposal must be carried out in accordance with applicable national legislation.

3 Product Description

3.1 Serial number & product name

Refer to the product nameplate.

3.2 Labels and safety signs

According to Fig. 1.

1. FUMEX logotype
2. Nameplate

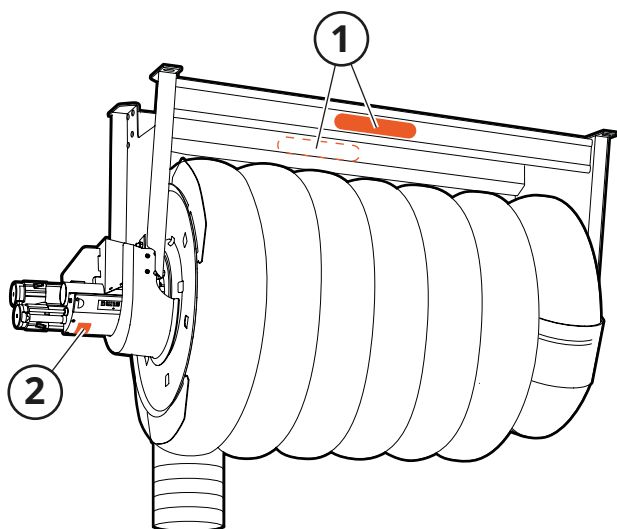
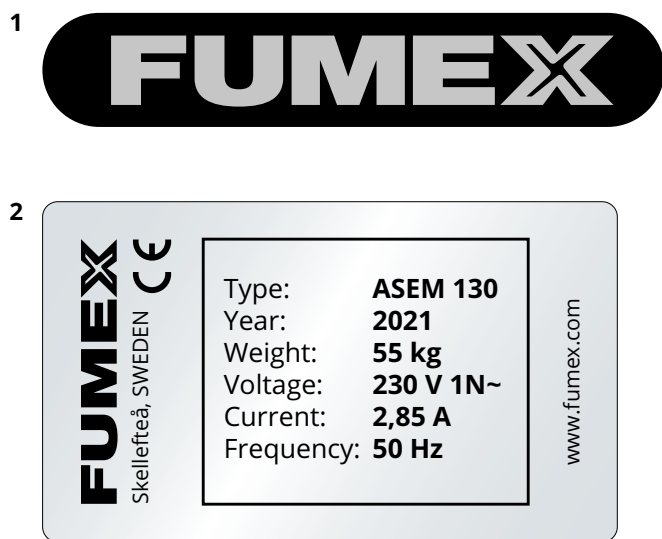

Fig. 1

3.3 Areas of use

FUMEX ASEM 130 is a motorised hose reel intended for the evacuation of exhaust gases.

3.4 Design

See Fig. 2.

- | | |
|--------------------|---------------------------------|
| 1. Bracket | 5. Hose |
| 2. Beam | 6. Motor |
| 3. Duct connection | 7. Declutching system |
| 4. Drum | 8. Contact safety device, motor |

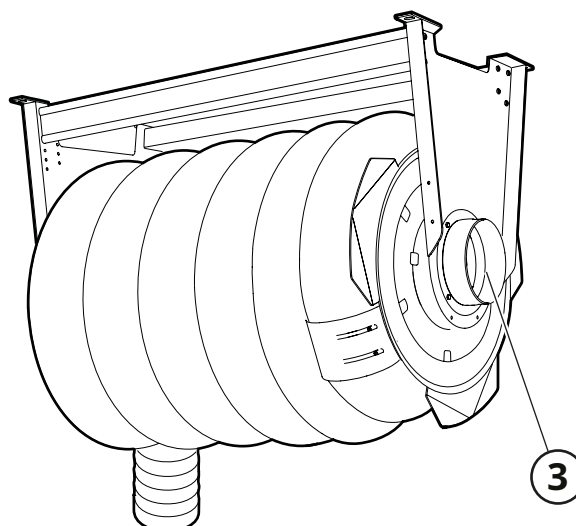
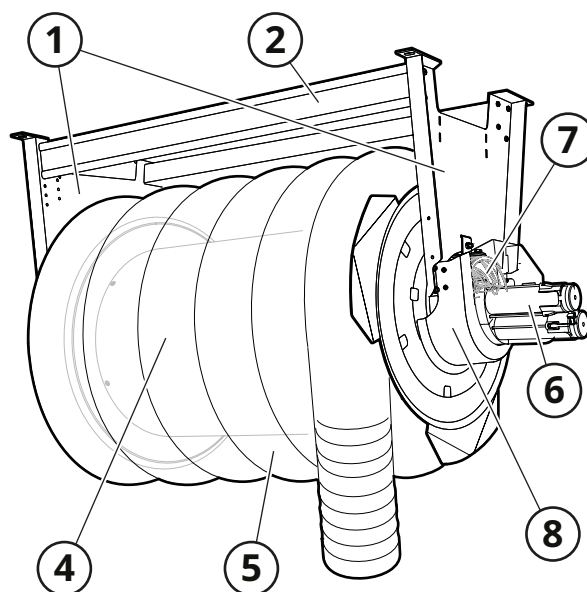

Fig. 2

3.5 Function

Contaminated air is sucked into the hose by a separate fan that is connected to the duct connection (3). The motor (6) controls how much hose is rolled out/in. Roll-out and retraction are started/stopped using the accessories ASEM 1, ASEM 2 and ASEM RADIO.

4 Preparation for use



Never work or stand underneath suspended loads!

When lifting and/or replacing parts, it is important that the lifting device is stable and secured. Only use suitable and technically sound lifting gear and load-bearing equipment with sufficient capacity.

4.1 Transport & storage



Protect the machine and its parts from rain, snow, aggressive atmospheres and other harmful effects.

4.2 Electrical equipment



The equipment is fed with high voltage and must always be equipped with a safety switch for service work in connection with the fan.



Note that electronic equipment is always sensitive to static electricity, high humidity and temperature as well as mains interference.

The choice of cable and cable area must comply with the national requirements applicable to fixed installations. For electrical installation, see Section **10.2 Circuit diagram electronics**.

4.3 Assembly & installation

National rules and regulations must always be adhered to during assembly work.

4.3.1 Unpacking

- Carefully unpack the product.



When buying a hose reel without a hose, leave the hose reel on the pallet to facilitate installation of the hose.

- Remove the wood screws securing the machine to the pallet.
- Check for any damage and missing parts. Contact a local FUMEX representative directly if there is damage or parts are missing.
- Dispose of the packaging material according to local recycling regulations.

4.3.2 Moving the machine



At least two people are required to move the machine.

4.3.3 Hose reel excluding hose



Hose reels including fitted hoses are not covered by sections **4.3.3 Hose reel excluding hose** to 4.3.5 Installing the hose.

Before installing the hose, set the drum position according to **Fig. 3** and **Fig. 4**. Follow the instructions in section **4.3.5 Installing the hose**.

Ceiling mounting

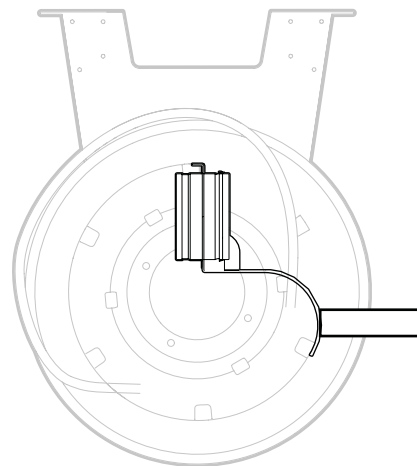

Fig. 3

Wall and floor mounting

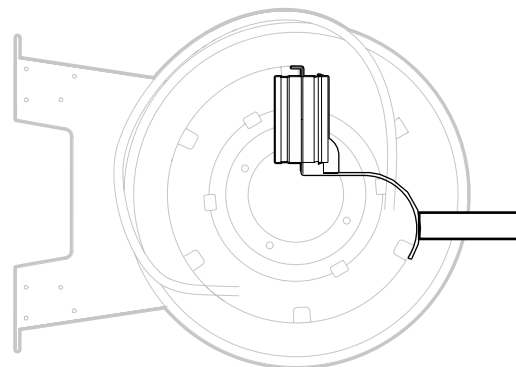

Fig. 4

4.3.4 Declutching the motor



The declutching lever must be drawn into/held in the declutching position by hand.

See Fig. 5.

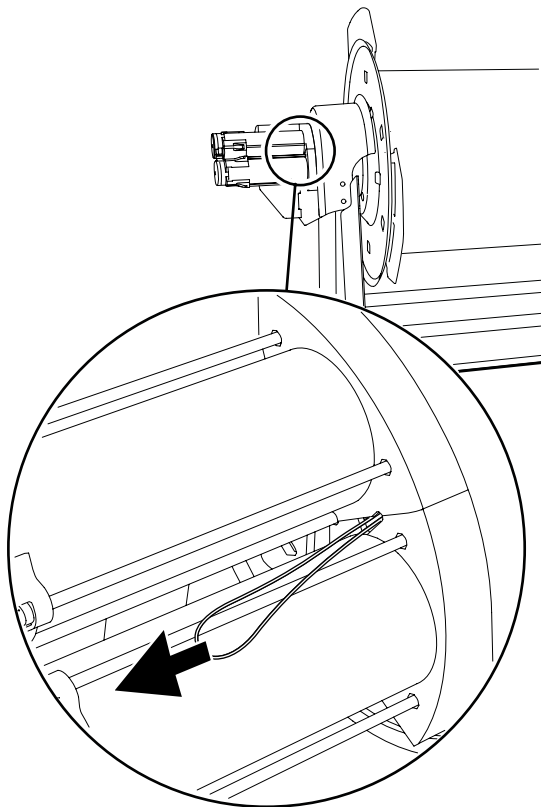

Fig. 5

4.3.5 Installing the hose



Hose installation is only relevant when buying a hose reel without a hose.

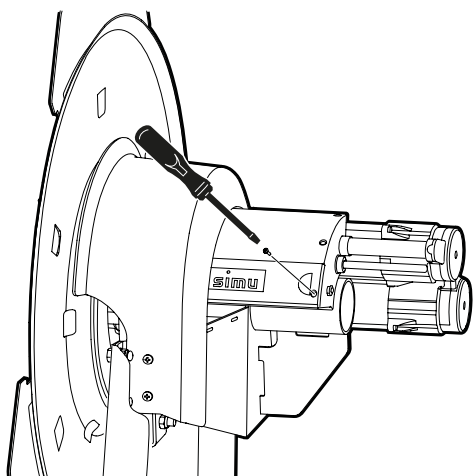

Fig. 6

1. Open the cover, see Fig. 6.

2. Disconnect the motor, see Fig. 5.



Fine adjustment of end positions is recommended when the hose reel is mounted and installed. See section 4.3.8 **Adjusting the end positions.**

3. **Coarse adjustment of end position for roll-out:**

Rotate the drum counterclockwise as viewed from the motor side until the roll-out wheel (3, Fig. 7) is obstructed by the stop clip (1). This is indicated by a rattling sound.

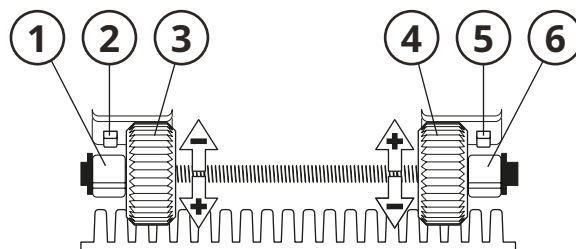

Fig. 7



When removing the safety clip for retraction and roll-out, an additional 1/3 turn is allowed before the switches stop the motor.

4. Continue unrolling the drum until the inlet is 1/3 turn before the desired end position. See Fig. 8 for mounting on the ceiling and Fig. 9 for mounting on the wall/floor.

Ceiling mounting

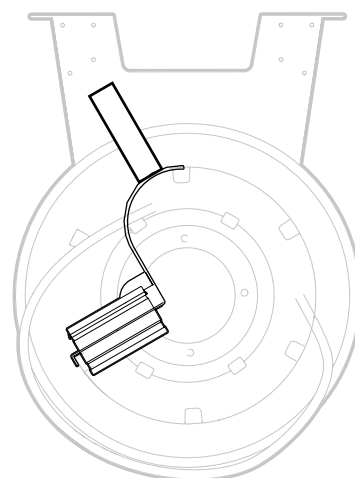

Fig. 8

Wall and floor mounting

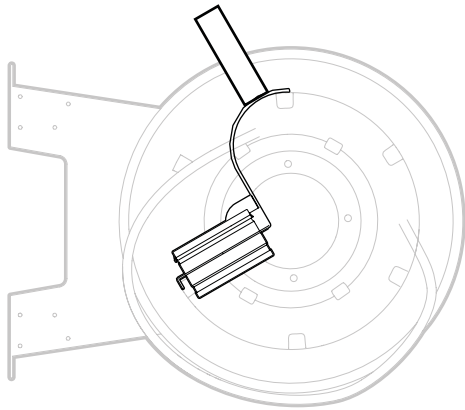

Fig. 9

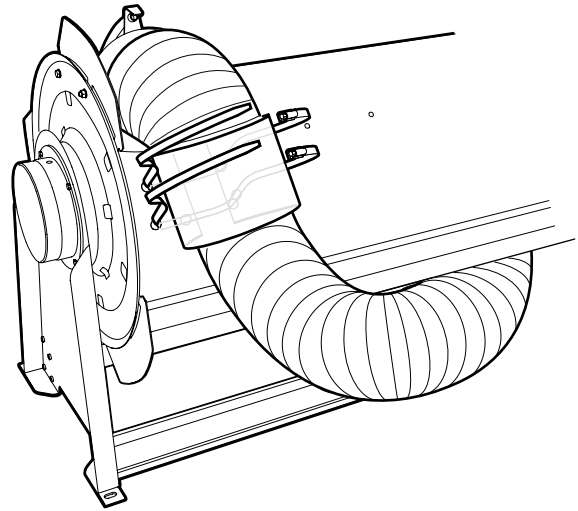

Fig. 11

- 5. Remove stop clip for roll-out (1, Fig. 7).
- 6. Install the hose (2, Fig. 10) with any reducer (1) on the hose reel connection with hose clamps (3).

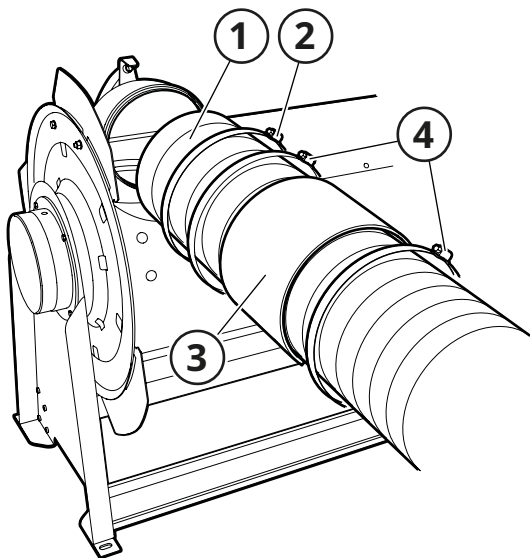

Fig. 10

- 7. Secure the hose using a rubber cloth and hose clamps according to Fig. 11.
- 8. **Coarse adjustment of end position for retraction:** Rotate the drum and roll in the entire length of the hose, or as much as fits on the width of the hose reel.
- 9. Remove stop clip for retraction (6, Fig. 7).
- 10. Release motor disconnect switch and refit the cover.
- 11. The hose reel is now ready for mounting and installation.

4.3.6 Mounting the hose reel



Fasteners used to mount the hose reel on the ceiling or wall must be dimensioned for the purpose.

The machine must be lifted into place using an approved platform (e.g. scissor lift). The platform must remain in place until the product is fully attached.

At least two people are required to mount the machine.



The hose must be secured.



To secure the hose, use AESM 100/125/150; see chapter 11 Accessories.



If the exhaust duct does not align with the mounted machine's duct connection, accessory ASL-160 can be used as a bridge.

- 1. Check the reel and ventilation ducts properly to ensure that foreign objects are not present. Remove any such objects immediately.
- 2. Mount the machine on the ceiling or wall.
- 3. Connect the exhaust duct to the machine's duct connection.

4.3.7 Installation

4.3.7.1 Electrical installation

A lockable safety switch (e.g. SSB 750) must be used for the input power supply so that safe servicing can be carried out.

The motor is supplied with 230 V 1N~ and installed together with control devices according to the circuit diagram (see section **10.2 Circuit diagram electronics**).

4.3.8 Adjusting the end positions



Incorrectly set end positions can cause serious personal injuries and property damage.



As standard, hose reels including hoses are supplied prepared for mounting on the ceiling.

The final position for retraction and roll-out varies and is adjusted by the customer. When adjusting end positions, consider the selected mounting method according to **Fig. 3** and **Fig. 4**.

1. Remove the screws and open the cover; see **Fig. 12**.

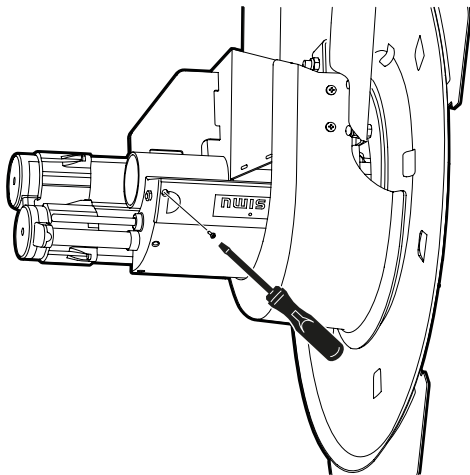

Fig. 12

2. Adjust end positions by turning the retraction and roll-out wheels (3, 4, **Fig. 7**).
3. When the final positions are set as desired, refit the cover on the motor.
4. The hose reel is now ready for operation.

5 Commissioning

5.1 Start-up



Any faults must be rectified before turning on the power.

1. Switch on the power supply.
2. Check the operation of the machine. White button for retraction, black button for roll-out.

6 Operation



Only equipment intended and approved for the product may be connected to the product, otherwise the operation of the product cannot be guaranteed.

When retracting and unrolling the hose, do not leave the hose/nozzle in a position where there is a risk of personal injury.



If the motor overheats, a temperature guard will switch on until the motor returns to the correct working temperature. Normally within 4–5 minutes.

In the event of a power failure, disconnect the motor to rotate the drum manually. See section **4.3.4 Declutching the motor**.

7 Troubleshooting



Troubleshooting with the power switched on may only be carried out by a licenced electrician.

7.1 Troubleshooting guide

The troubleshooting guide contains information for identifying faults which are simple to rectify. Always perform the troubleshooting procedures before contacting FUMEX.

TROUBLESHOOTING GUIDE		
Symptom	Possible cause	Recommended action
1. The hose does not stop in the correct position.	Incorrect end positions have been set.	Adjust the end positions; see section 4.3.8 Adjusting the end positions.
2. The motor cannot retract the hose.	Hose is too heavy.	Use shorter or lighter hose; see torque under section 10.1 Technical data.
	Nozzle is too heavy.	Use lighter nozzle; see torque under section 10.1 Technical data.
3. Noisy bearing.	The negative pressure in the system is too high.	Lower the negative pressure (max. 2,500 Pa).
	Bearing worn out.	Replace bearing.
4. Poor suction.	Leakage in gasket/connection.	Check that the gaskets and connections are tight. Rectify if necessary.
	Foreign objects in suction tube.	Check the suction tube. Remove any foreign objects.
	Hole in hose.	Check the hose and replace if necessary.

8 Maintenance



Please remember that only original spare parts may be used.

Make sure that all moving parts are secured to prevent unintentional movement.

8.1 Cleaning

The product should be cleaned with clean cloths and neutral detergents to avoid damage.

8.2 Maintenance schedule



Depending on the changing operating conditions between the different systems, the intervals for recommended maintenance may differ. Users should therefore determine their own maintenance intervals.

The checklist for maintenance is designed for normal use of the machine. The recommended intervals are approximate and refer to the time after the first start-up.

FUMEX recommends the following maintenance schedule:

MAINTENANCE SCHEDULE				
Interval	Item	Inspection module	Maintenance instructions	Date
As necessary	1.1	Hose	Check that the hose is intact. Replace as necessary.	
	1.2	Hose reel	Clean the hose reel externally with a damp cloth.	
Every three months	2.1	Hose	Check the attachment of the hose.	
	2.2	Hose reel	Check for leaks, damage and wear.	
Once a year	3.1	Duct system	Check dust accumulation. Clean if necessary.	

9 Decommissioning

9.1 Final decommissioning/ disassembly/disposal

Final decommissioning and disassembly of the product may only be done by authorised personnel wearing protective gear. The handling and correct removal of the various types of materials must be in accordance with the applicable legal requirements.

Please contact FUMEX if you have any questions about the various types of waste.

10 Technical information

10.1 Technical data

Dimensions (mm): See **Fig. 13**

Weight¹: 55 kg

Voltage: 230 V 1N~

Frequency: 50 Hz

Current: 2,85 A

Enclosure class: IPX4

Speed: 10 rpm

Torque: 200 Nm

Max. rolled-up hose²: 11,5 m

Temperature limits

Operating temperature³: 5°C to 650°C

Ambient temperature: 5°C to 40°C

Transport and storage temperature: -20°C to 50°C

¹ Excluding hose.

² FUMEX hose AG Ø200 mm.

³ Temperature resistance depends on hose selection.
See specification in exhaust hose product sheet.

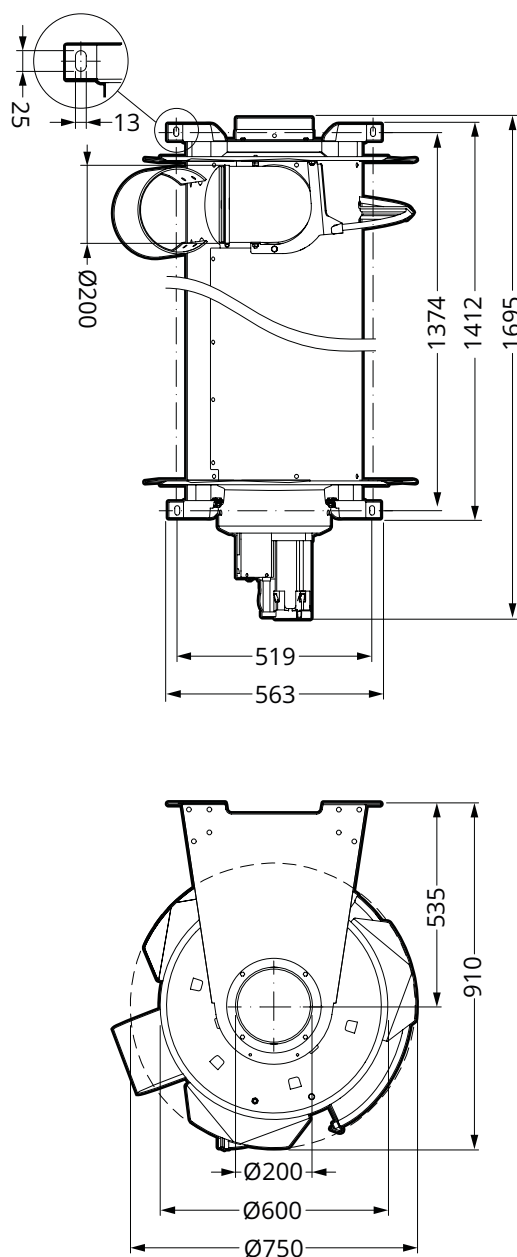
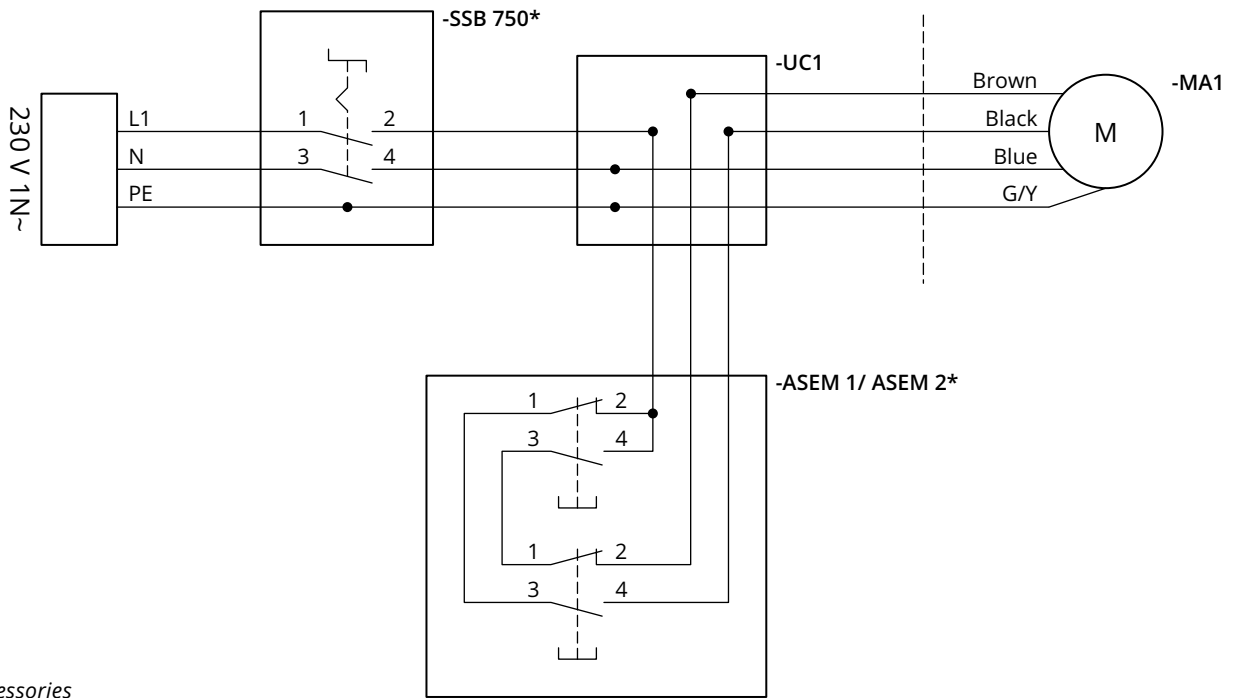

Fig. 13

10.2 Circuit diagram electronics

10.2.1 ASEM 1 / ASEM 2



* Accessories

10.2.2 ASEM Radio

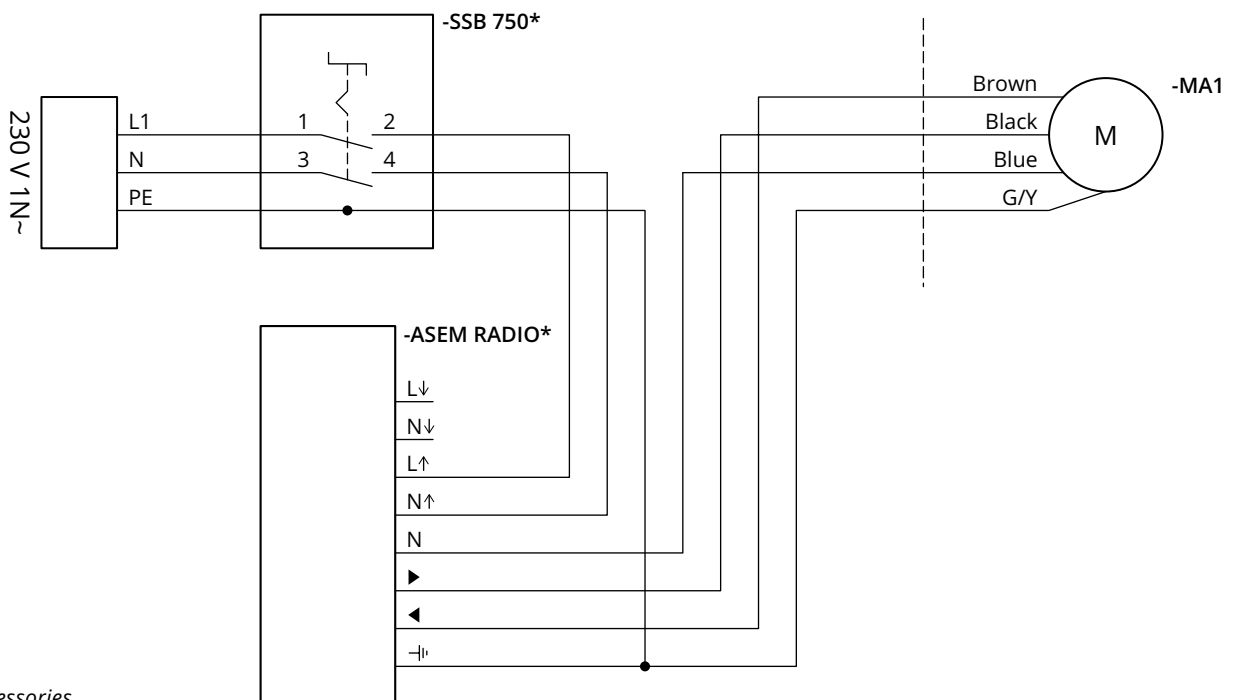

* Accessories

10.3 Exploded-view drawing

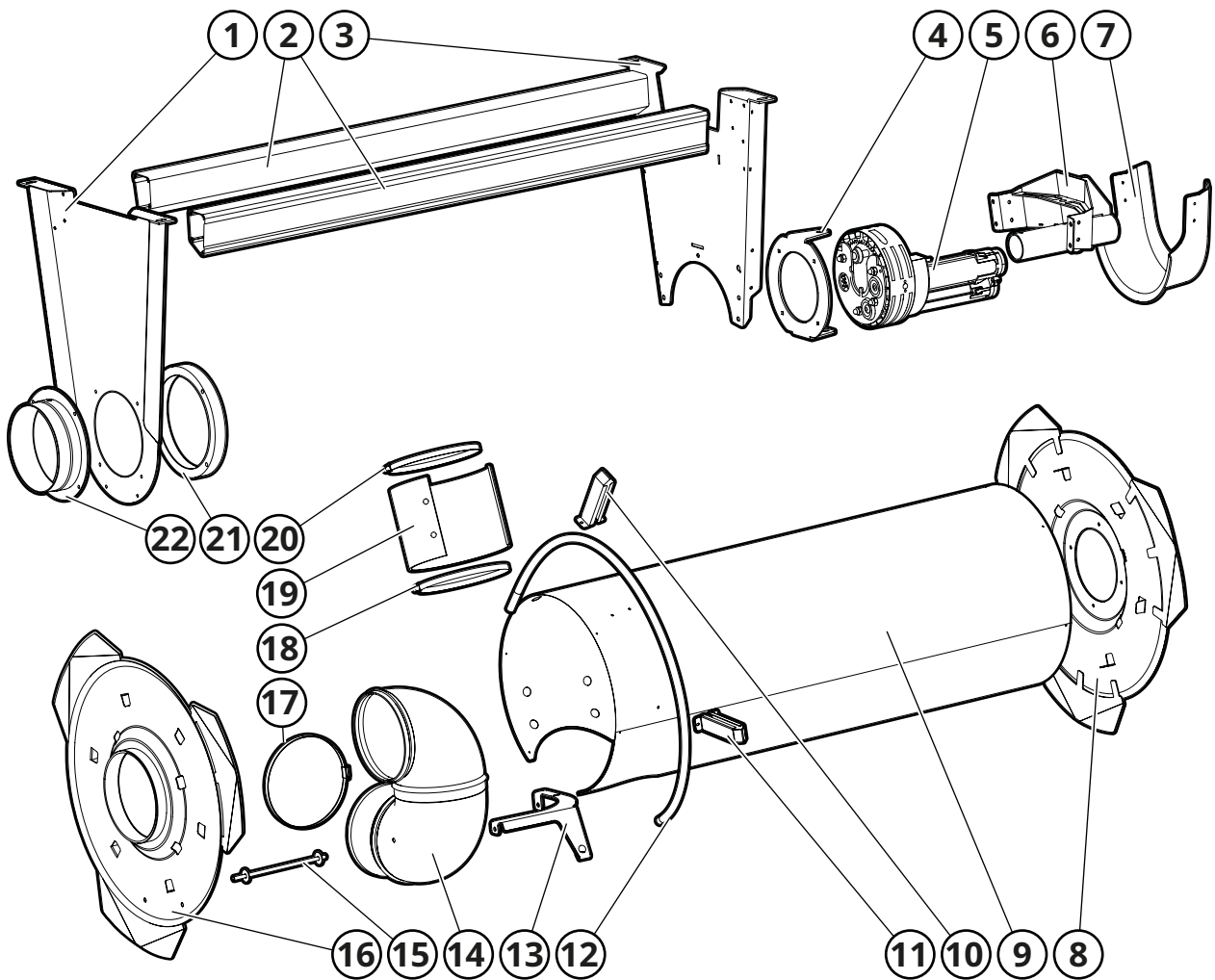

11 Accessories

ASE 865 – Switch for controlling fans/electric dampers

Externally mounted. Activated by the rotation of the hose reel. Automatic start/stop of fan and electric damper. Max 24 V supply voltage. For a complete system, the FUMEX S 600/S 400 control unit must be used (refer to the separate product sheet Automatic Control Units for Vehicle Exhausts).

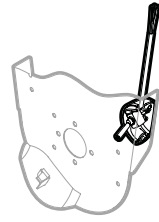

ASES 200 – Automatic mechanical damper

For fitting to the connection sleeve. Activated by the rotation of the hose reel. The damper has a clear indicator that shows whether the damper is open or closed. ASES is an energy-saving accessory. Combine with fan pressure control to further optimise the system.



AESM 200

Hose installation kit with hose clamps, protective cloth and any reducer. Hose clamps and reducers are made of galvanised steel sheet, hoses and protective cloths are made of EPDM rubber.

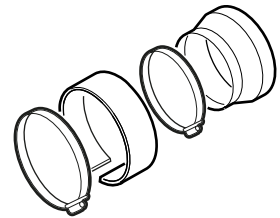

ASL 200

0.2 metre hose with hose clamps for connecting the hose reel and duct.

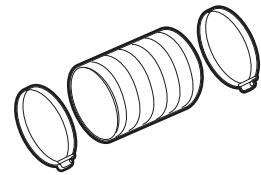

Safety switch SSB 750

With lockable toggle. Two M25 bushings included.

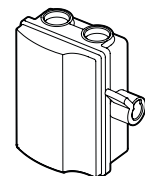

Control devices

Used to reel the hose in and out easily and conveniently, while helping to prevent work-related injuries.

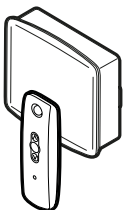

ASEM RADIO

Radio control set (transmitter/receiver). IP 55. Designed for operating and protecting fan motors.

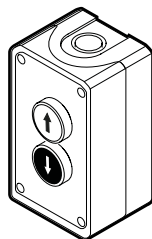

ASEM 1

Wall-mounted control device. IP 66.

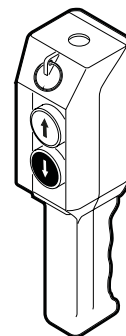

ASEM 2

Hanging control device. IP 65.

12 Notes

EXTRACTION ARMS • VEHICLE EXHAUST EXTRACTION • FANS • FILTERS • CURTAINS • CONTROLS

FUMEX

Verkstadsvägen 2, 93161 Skellefteå, Sweden • Tel.: +46 910-361 80 • Fax: +46 910-130 22 • E-mail: info@fumex.se
www.fumex.com