



PSS

High-quality, acid-resistant extractor arm in stainless steel for stringent sanitary requirements



CLEANROOM
CERTIFIED



FOOD
GRADE



ATEX
COMPATIBLE

FUMEX

PURE ADVANTAGE

EASY CLEANING:

- High-gloss polished ($Ra \leq 0,6$) acid-resistant steel
- **FUMEX Q-Maid™** quick hose connection (suspension and attachment)
- Detachable protective grille
- Component-free airflow
- Fully sealed profile
- Few components for easy cleaning
- Food-grade certified hose
- Food-grade certified stainless steel gas spring
- Dual grounding for maximum safety

Fully stainless steel extractor arm for demanding work environments

FUMEX PSS - Cleanroom certified extraction arm with a smart and stylish design developed primarily for industries with strict hygiene requirements, such as the food and pharmaceutical industries. A design based on the fundamental Fumex principle of using external support arms, which produce the lowest possible pressure drop and pose little risk of blockage. All surfaces finished in high-gloss polished ($Ra \leq 0,6$) acid-resistant stainless steel, and the antistatic hose is fitted with quick connectors, making PSS the most easily cleaned extraction arm in the industry. FUMEX PSS is available in the lengths 2000, 3000 and 4000 mm and the dimensions $\varnothing 100$, 125, 160 and 200 mm.

Q quick
M maintenance
A assembling
I installation
D dismantling



What is FUMEX Q-Maid™?

FUMEX Q-Maid™ is a quick connection system that simplifies maintenance, assembly, installation and disassembly.



**CLEANROOM
CERTIFIED**



**FOOD
GRADE**



**ATEX
COMPATIBLE**

Cleanroom, ATEX, "Food Grade", fully sealed profile and few components in a unique combination

On the **FUMEX PSS**, both hose and gas spring are food grade, and the finish of the high-gloss polished steel is top class. In addition, the support arms have a fully sealed profile.

Other components are both non-toxic and few, which overall makes the work of keeping the equipment sanitary over time significantly easier than similar products on the market.

The extraction arm is ATEX compliant and meets the requirements of the ATEX directive for category 2 equipment for gas and dust, and it is suitable for use in zones 1 and 21 as well as 2 and 22.

Cleanroom certified

Cleanrooms are controlled work environments that require low levels of environmental contaminants such as dust, airborne microbes, aerosol particles and chemical vapors. This places high demands on equipment to be used in these environments.

FUMEX PSS is cleanroom tested and certified by a third party. The certificate means that FUMEX PSS meets the authorities' requirements and is an approved extraction arm for cleanroom-controlled work environments.

ATEX labelling

Fumex ATEX-compliant extraction arms are labelled with a nameplate providing information on the explosive atmospheres for which the product is suitable. The nameplate is structured as follows:

- 1 ATEX code
- 2 Type of protection (non-electrical)
- 3 Gas/Dust group
- 4 Temperature class
- 5 Equipment protection level

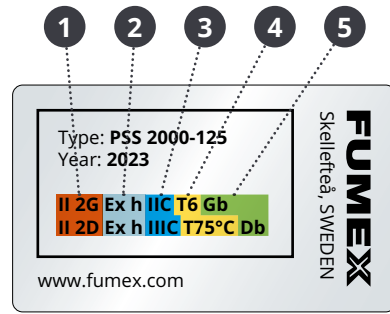

1

Equipment group	
Group	Area
I	Below ground
II	Above ground

2

Type of protection (non-electrical)	
Symbol	Type of protection
h	Protection through design safety non-electrical equipment

Equipment category	
Group	Zone
M1	Energised
M2	Non-energised
1	Very high protection
2	High protection
3	Normal protection

3

Gas groups	
Group	Example
I	Methane
IIA	Propane
IIB	Ethylene
IIC	Hydrogen

4

Temperature class gas	
Class	Max. surface temp.
T1	450 °C
T2	300 °C
T3	200 °C
T4	135 °C
T5	100 °C
T6	85 °C

5

Equipment protection level	
Level	Zone
Ga	0
Gb	1
Gc	2
Da	20
Db	21
Dc	22
Ma	Energised
Mb	Non-energised

Gas	Dust
G	D

Dust groups	
Group	Example
IIIA	Combustible
IIIB	Non-conductive
IIIC	Conductive

Temperature class dust	
Max. external surface temp.	

ATEX

Zone classification

Potentially explosive areas or premises must be classified in zones according to the frequency of occurrence and duration of explosive atmospheres. The person responsible for the operations is responsible for ensuring the classification of such risk areas.

Classification shall be conducted by persons knowledgeable about the properties of any flammable goods, the process and the equipment. Classification can be conducted in consultation with protection and electrical engineers as well as process technicians.

Zone 0 and Zone 20

An area in which explosive atmospheres are present continuously, for long periods or frequently.

Zone 1 and Zone 21

An area in which explosive atmospheres are expected to occur during normal operations.

Zone 2 and Zone 22

An area in which explosive atmospheres are not expected to occur during normal operations but, if they do occur, only last for a short time.

Dimensional drawing (mm)

PSS 2000/3000

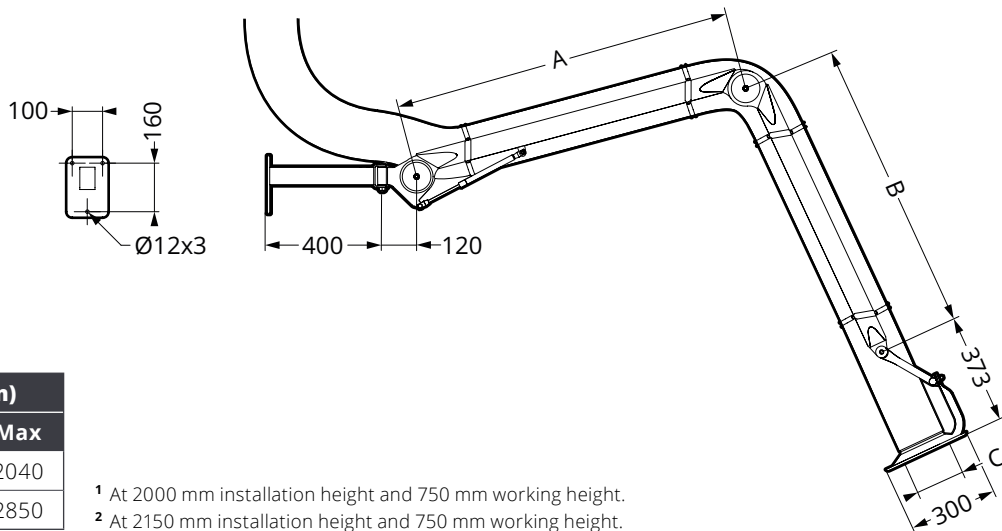

WORKING RADIUS (mm)		
Model	Min	Max
PSS 2000 ¹	0	2040
PSS 3000 ²	0	2850

¹ At 2000 mm installation height and 750 mm working height.
² At 2150 mm installation height and 750 mm working height.

DIMENSIONS (mm)			
Model	A	B	C
PSS 2000	650	750	Ø100/125/160/200
PSS 3000	1150	1000	Ø100/125/160/200

PSS 4000

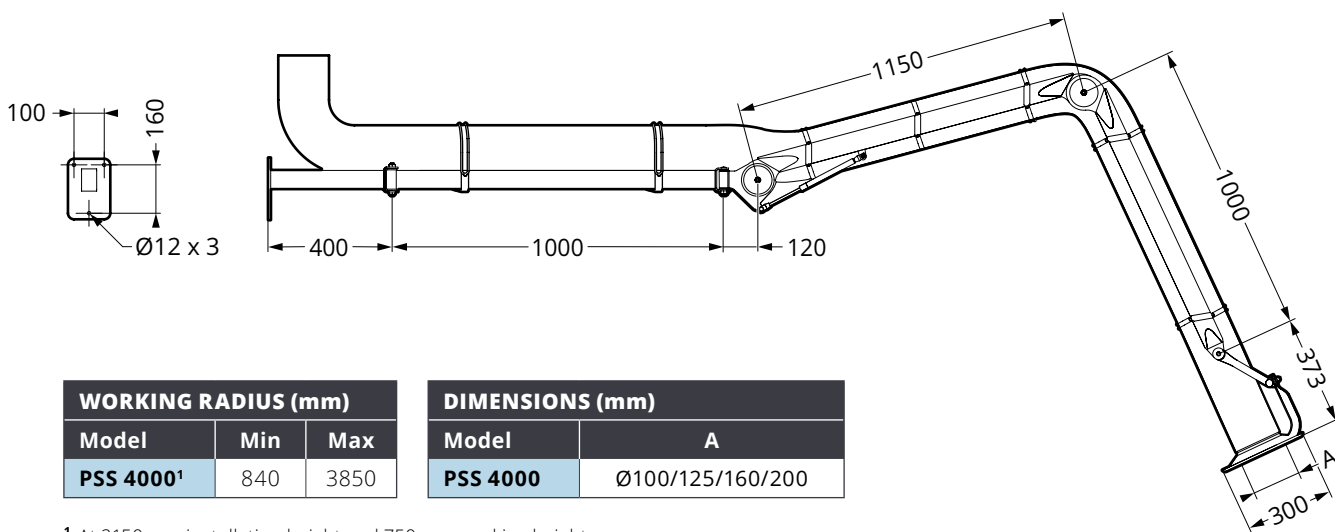

WORKING RADIUS (mm)		
Model	Min	Max
PSS 4000 ¹	840	3850

DIMENSIONS (mm)	
Model	A
PSS 4000	Ø100/125/160/200

¹ At 2150 mm installation height and 750 mm working height.

Pressure drop diagram

PSS Ø100 mm

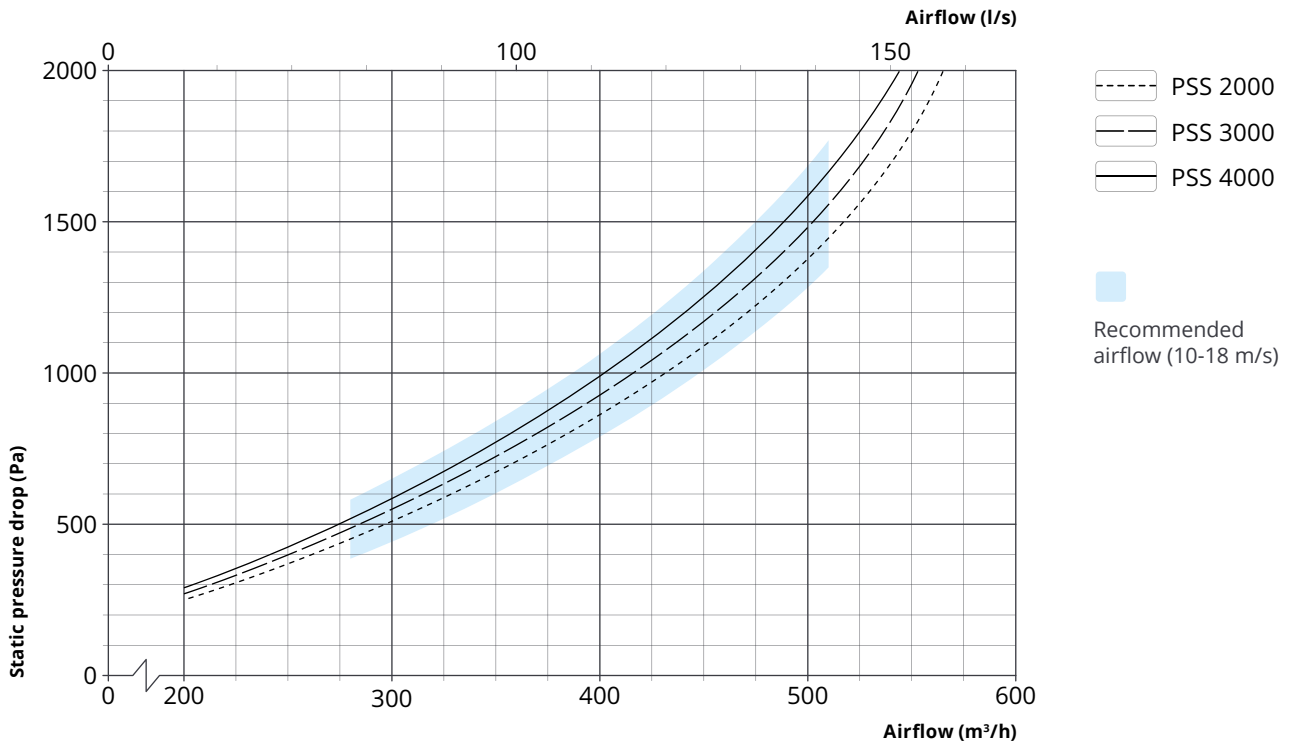

PSS Ø125 mm

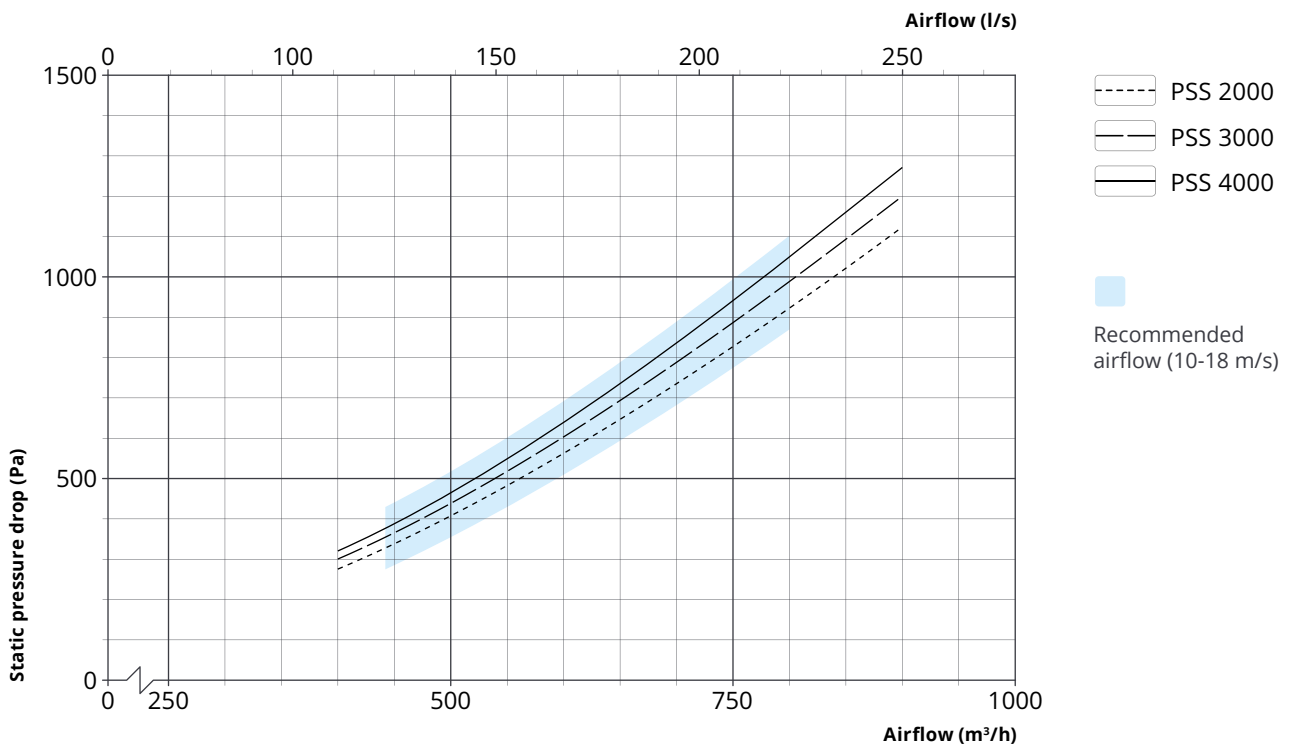

PSS Ø160 mm

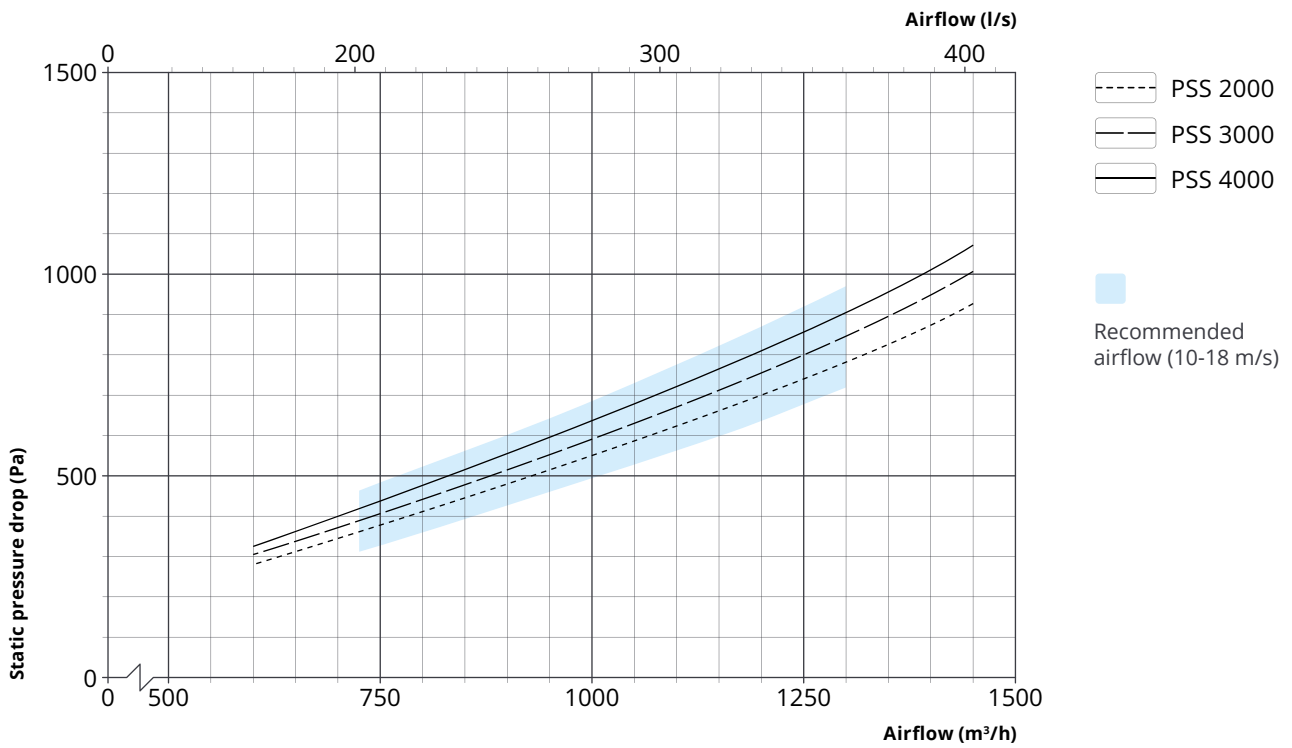

PSS Ø200 mm

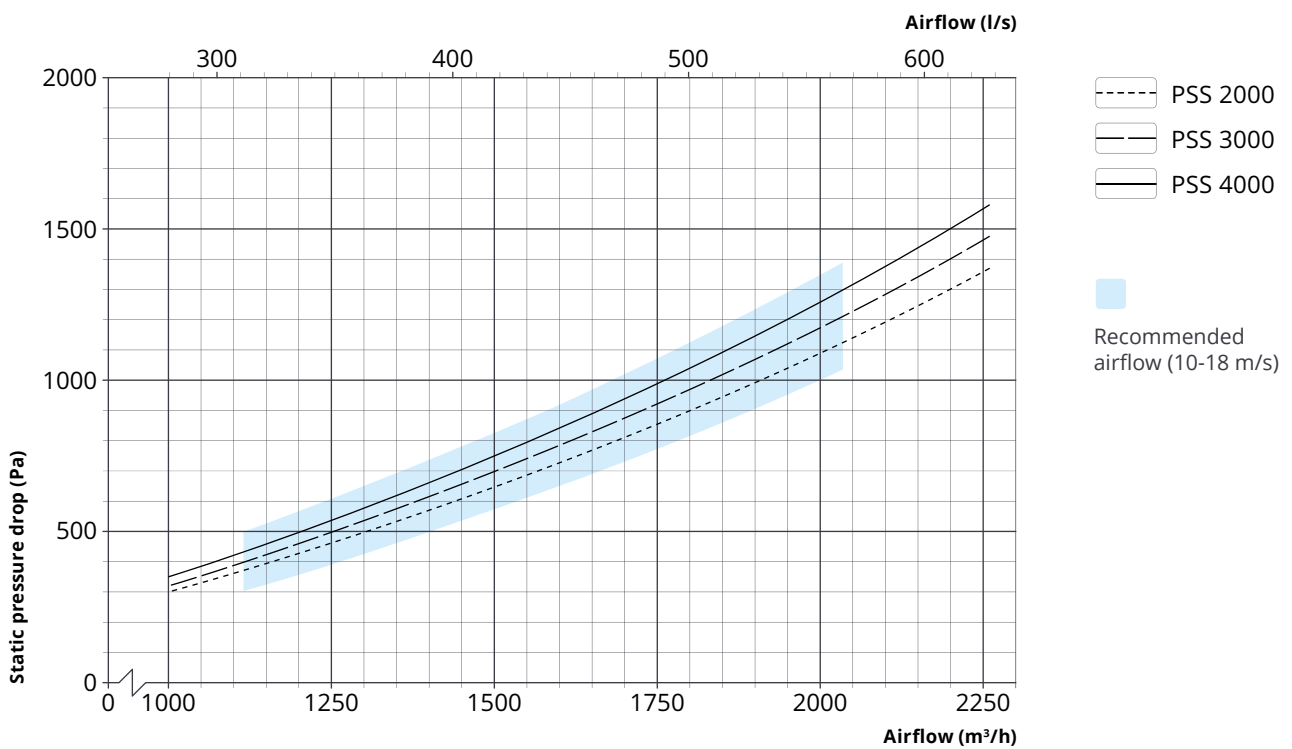

Accessories



Ceiling bracket PTA4
Ceiling bracket in acid-resistant stainless steel.

Lengths:
500/1000/1500 mm



Floor bracket PGA4
Floor bracket in acid-resistant stainless steel.

Length:
2200 mm



Rotation link PLA4
Extension link in acid-resistant stainless steel for 180° of additional rotation.

Length:
220 mm



Damper PSSMS¹
Damper in acid-resistant stainless steel. Easy to assemble/disassemble for quick and easy cleaning.

Dimensions:
Ø100/125/160/200 mm

¹ The damper must be factory installed to guarantee the function of the earthing.

Specifications

Form of delivery

The extraction arm is delivered partially assembled with a wall bracket for easy installation.

Production

Since the product does not have an internal ignition source, it cannot be certified under the ATEX directive 2014/34/EU.

Certificate

Cleanroom certified (TÜV SÜD, certificate no.: 3801499-00), Class ISO 6 according to DIN EN ISO 14644-1 (corresponds to GMP class C regarding the particle sizes). The certificate is limited to air cleanliness by particle concentration.

Surface treatment

Structural components and hood: High-gloss polished Ra ≤0,6 acid-resistant stainless steel (A4), grade EN 1.4401 / AISE 316
Plastic components: PP, PA6, TPU (FDA)
Rubber components: EPDM (FDA)

Versions

PSS	2000	3000	4000
Length (mm):.....	2293	3043	4043
Weight ¹ (kg):.....	10,1	11,2	16,2

Hose

Properties: Permanent antistatic PU hose with stainless steel coil, R <10⁹ Ω
Temperature range: ...-40 °C to +100 °C
Dimensions (Ø): 100/125/160/200 mm

Resistant to hydrolysis and microbes, non-toxic, and food-grade certified in accordance with EC Regulation No. 1935/2004 and No. 10/2011, FDA standards 21 CFR 177.2600 and 178.2010.

¹ Excluding hose.